

Model Based Design of a Fuel Cell Vehicle

Efficient development of fuel cell simulation models

Alexander Hlawenka
Product Manager - FClib

Fuel Cell Seminar
Phoenix
Oktober 30th, 2008

Content

- What is model based design?
- Fuel cell vehicle
- FClib
- Model Based Design

Model Based Design of a Fuel Cell Vehicle

Development process

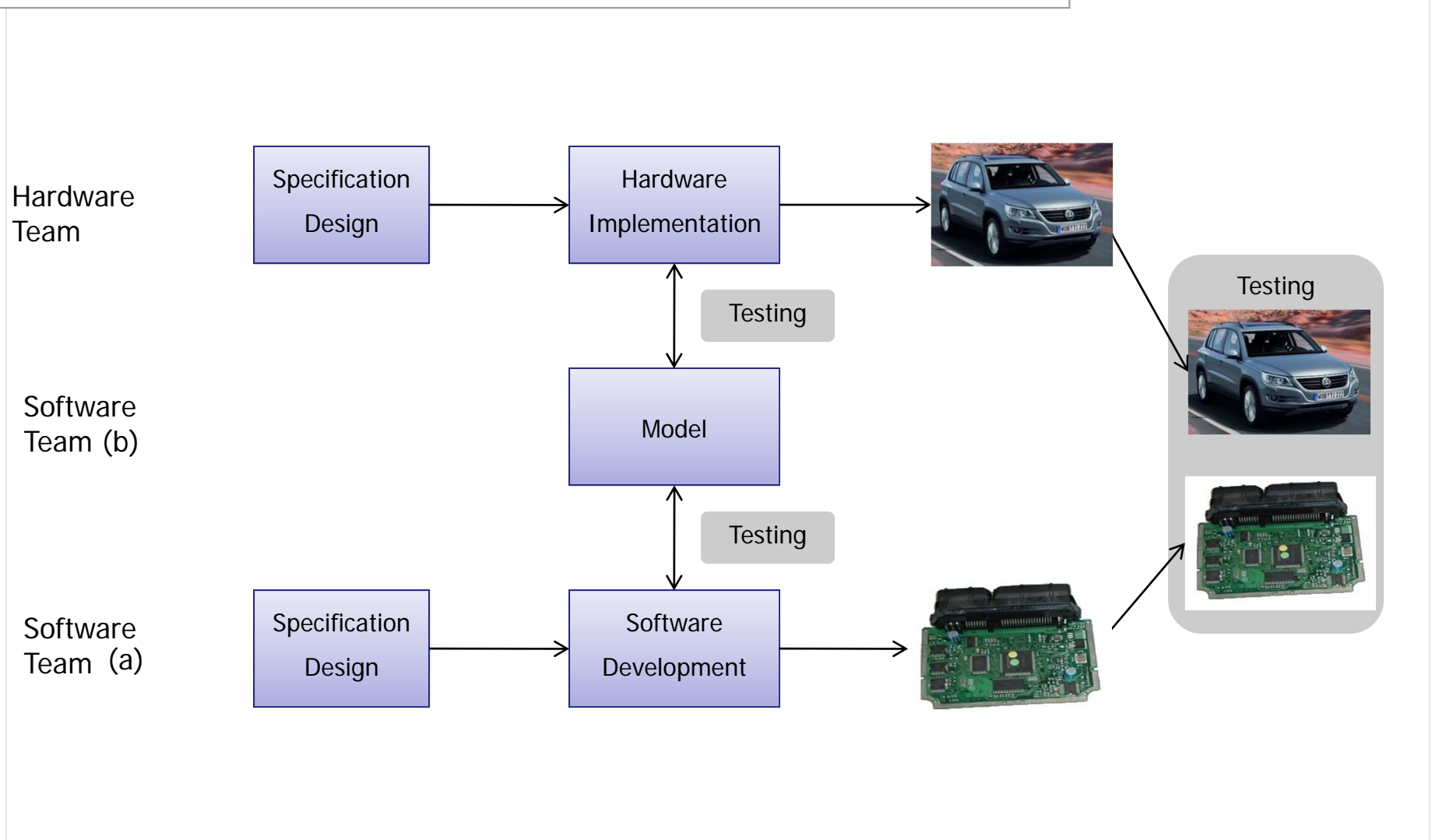

Model Based Design of a Fuel Cell Vehicle

Model Based Design

- MBD we understand as
 - a development paradigm for control applications
 - guided by a process model

- MBD allows for ...
 - ... early testing of control applications against a realistic process behavior
 - ... process design optimizations before process implementation
 - ... shortens your commissioning time dramatically

Model Based Design of a Fuel Cell Vehicle

The process: Fuel cell and drive train

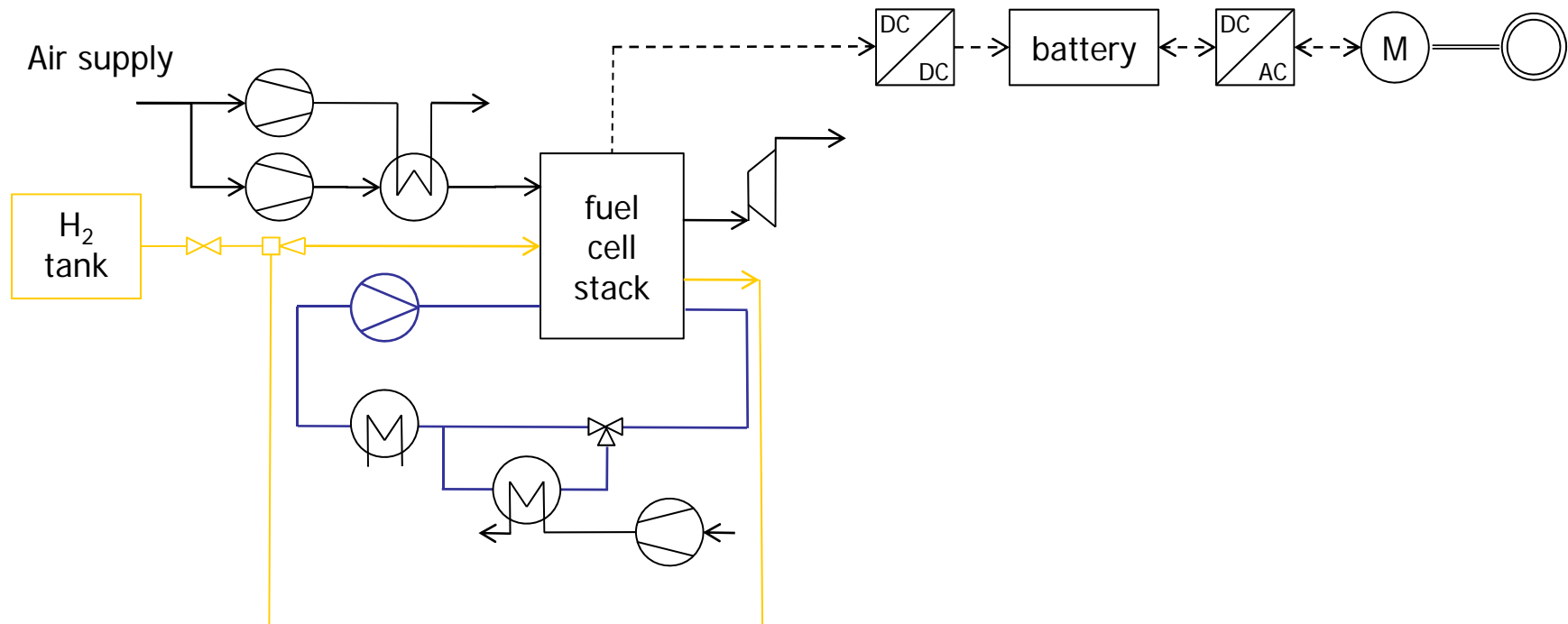

H₂ recirculation

- Air supply and exhaust gas
- Hydrogen
- > Electrical Power

Model Based Design of a Fuel Cell Vehicle

The process model – top level view

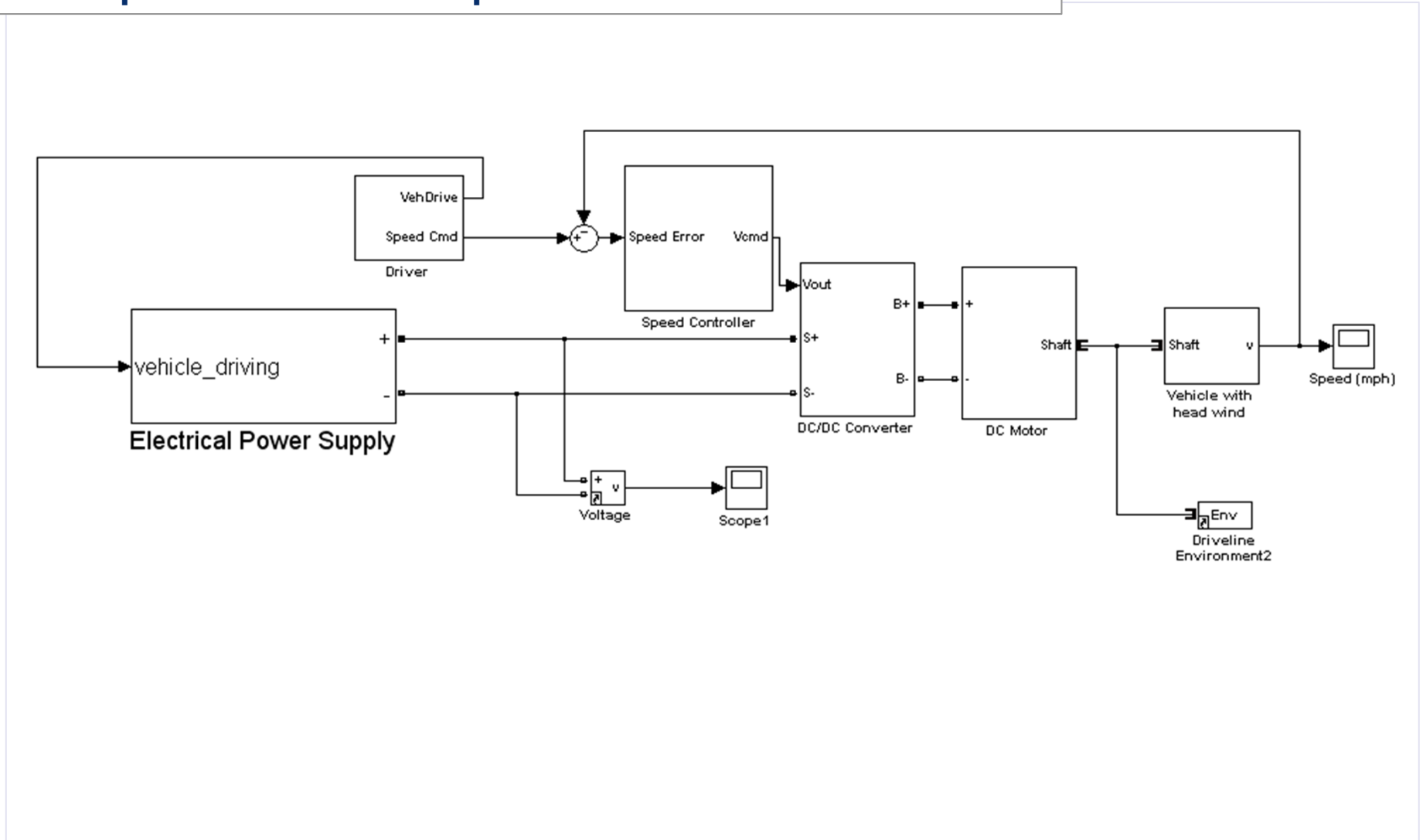

Model Based Design of a Fuel Cell Vehicle

The process model – developed using libraries

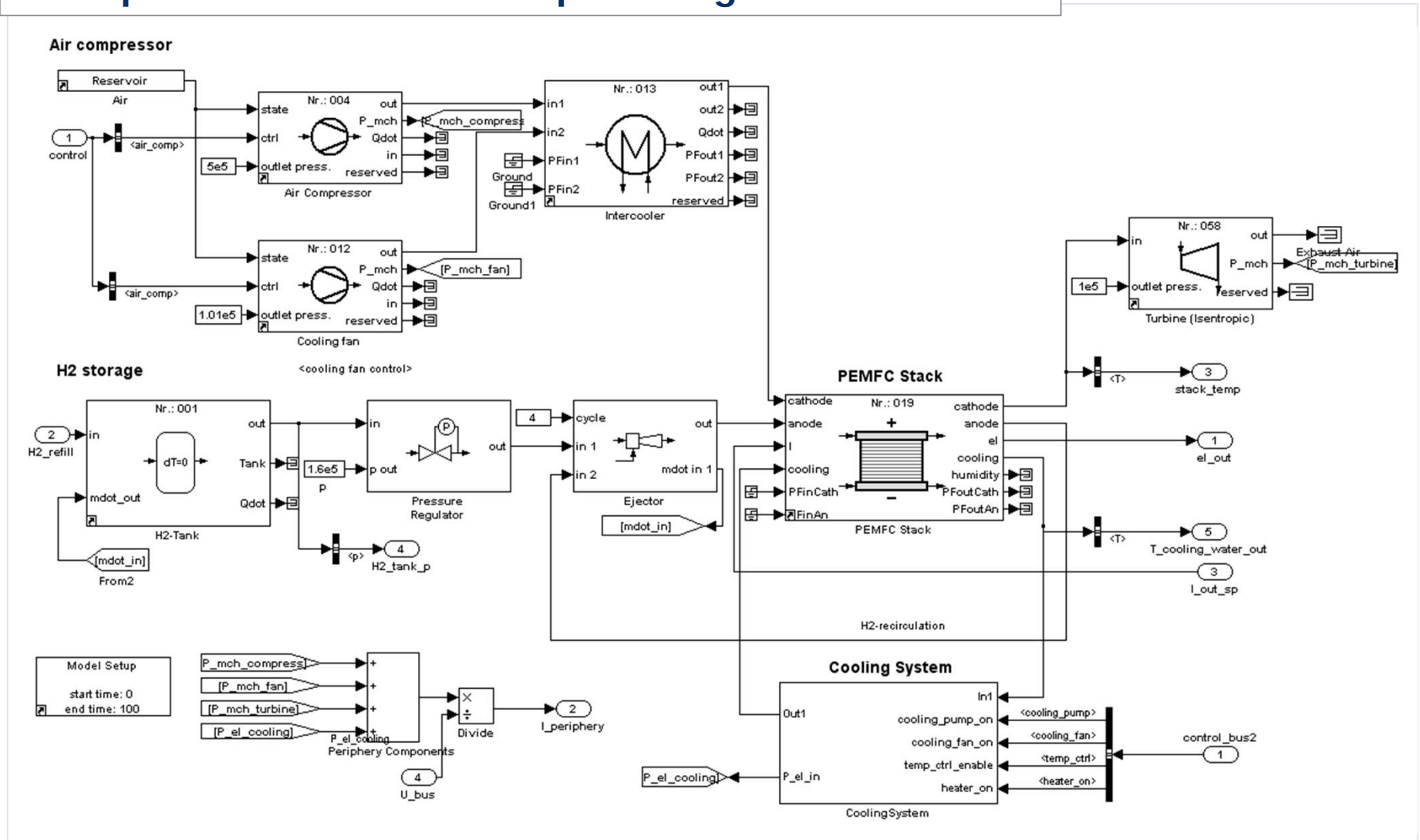

Model Based Design of a Fuel Cell Vehicle

Process model: features

- Model contains multiple physical domains
 - thermodynamic components
 - reaction chemistry
 - mechanical components
 - electrical components
- Build using available library blocks for physical modeling
- Parameter can be adjusted to measurements
- System level modeling

Model Based Design of a Fuel Cell Vehicle

The controller model - detail

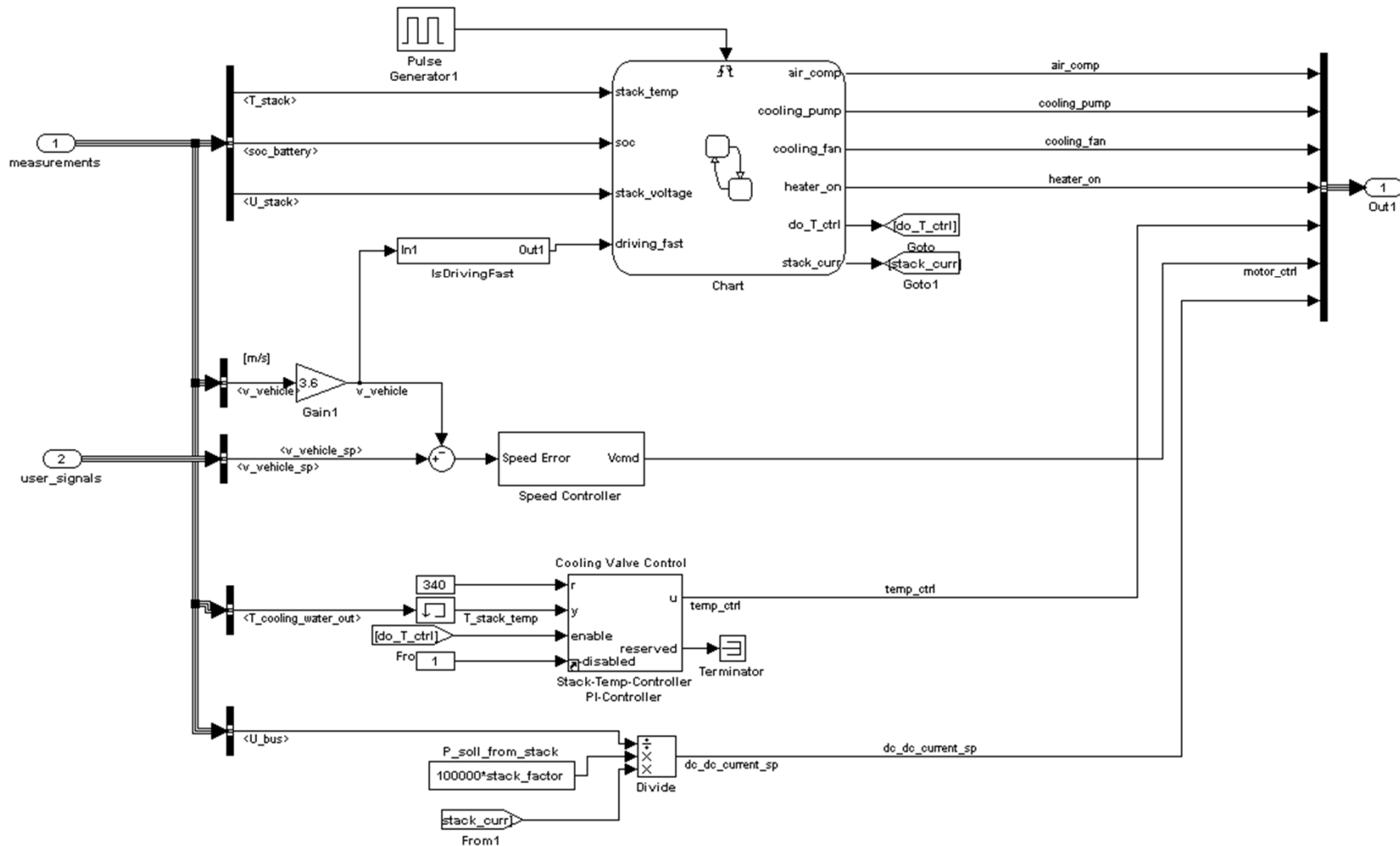

Model Based Design of a Fuel Cell Vehicle

Controller model: features

- PI-Controllers
- Feed forward controls
- State machines
- Signal supervision (alarm generation)
- Remanent data storage
- etc.

Model Based Design of a Fuel Cell Vehicle

Development process

- Model-in-the-loop
- Hardware-in-the-loop

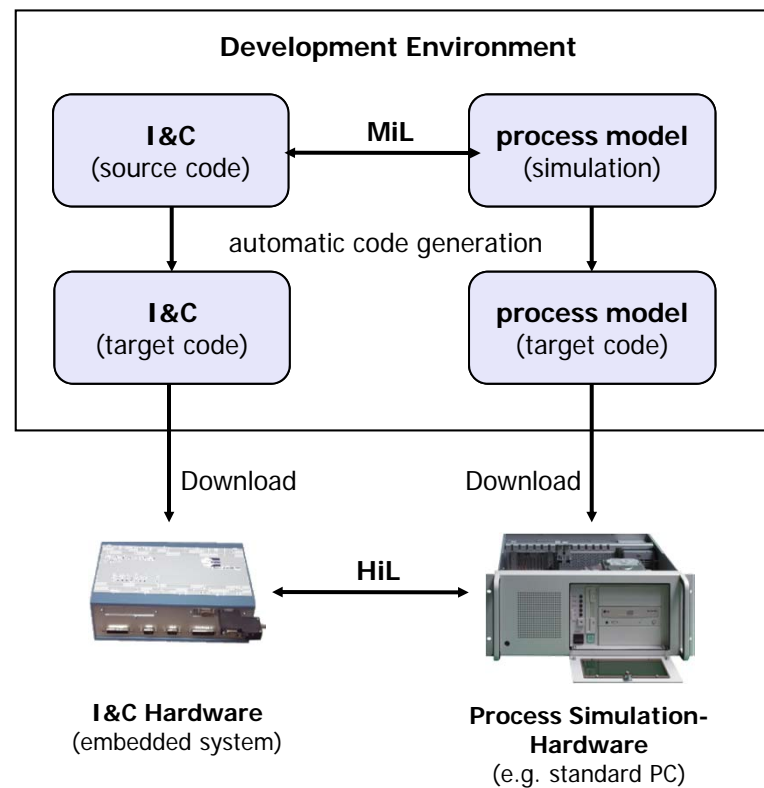

Model Based Design of a Fuel Cell Vehicle

Model-in-the-loop

- Classic approach:
 - replay static inputs to the controller
 - no reaction to controller outputs
- Closing control loops enables realistic testing
 - interaction between process model and controller
 - testing behavior at complex process failures
 - save testing environment

Hardware-in-the-loop

- e. g. Testing the final embedded hardware against a process model
- final I/O and communication

Model Based Design of a Fuel Cell Vehicle

Hardware-in-the-Loop

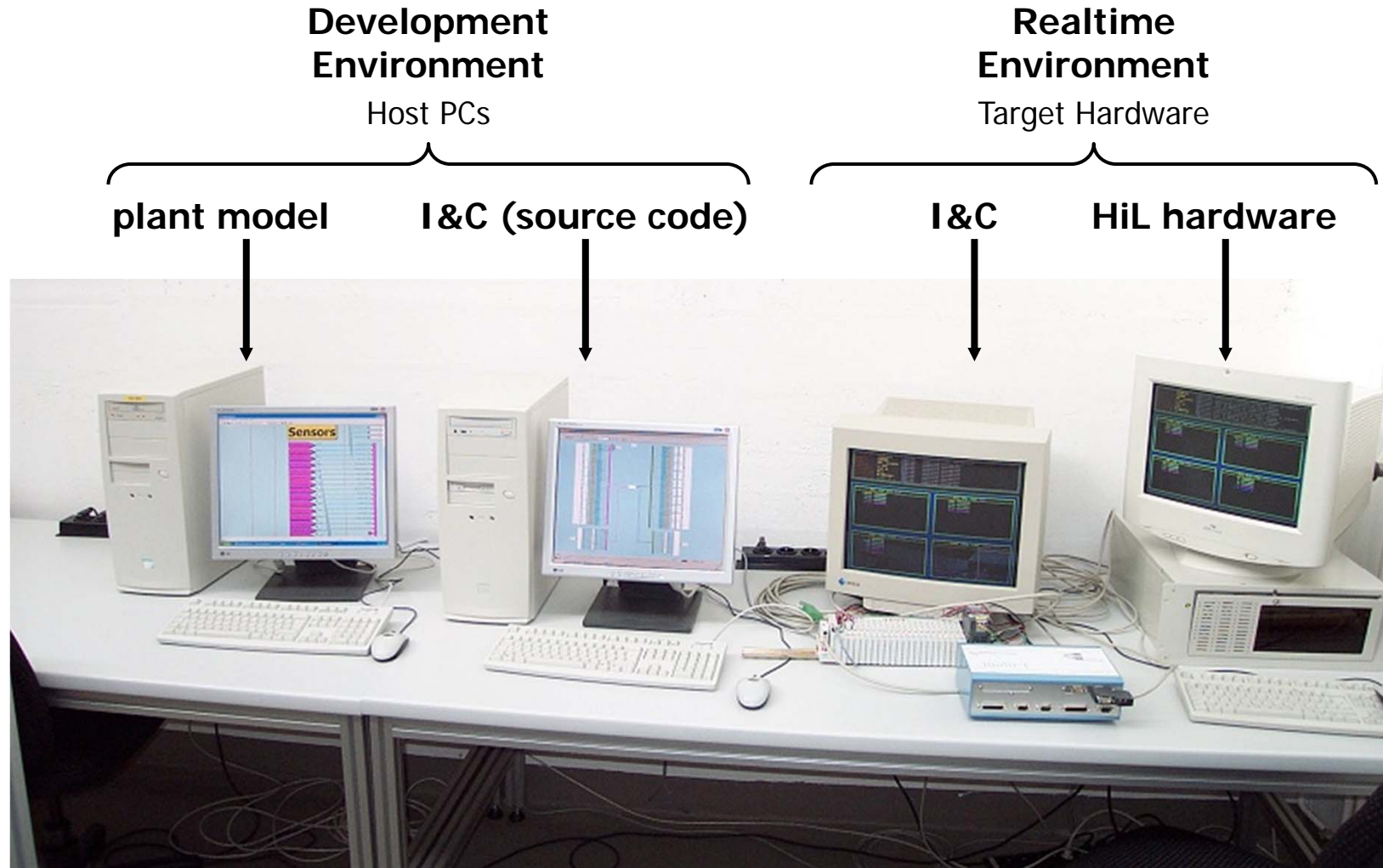

Model Based Design of a Fuel Cell Vehicle

Simulation Results – detail of a US06 cycle

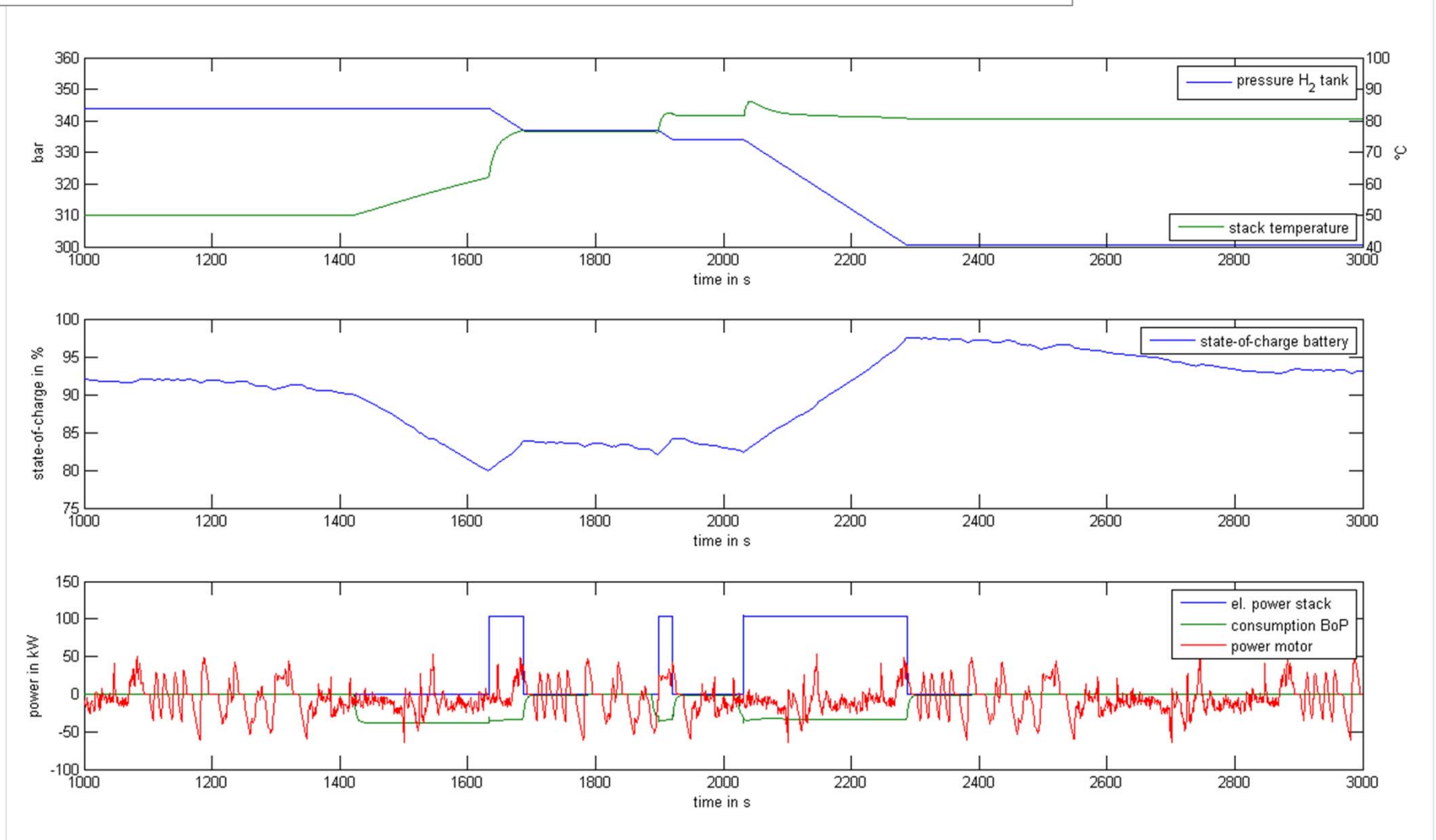

Model Based Design of a Fuel Cell Vehicle

What's the message?

- Design your controller using a process model! Do Model Based Design.
- Use Hardware-in-the-loop testing to verify your controller
- Use available libraries for system modeling!