

Non-thermal Plasma Reforming For TARDEC

L. Frost

S. Elangovan

J. Hartvigsen



CERAMATEC®
TOMORROW'S CERAMIC SYSTEMS

Project Objective

- **Project funded by TARDEC**
- **Design, fabricate, and deliver a 10 kWe JP-8 reformer**
 - Based on 30 % efficient fuel cell (i.e. ~ 33 kWt reformer)
 - Must include sulfur removal unit
 - Must be capable of cold start
- **Ceramatec was prime on the contract**
- **Teamed with Drexel University and IntraMicron**
 - Drexel provided an alternative design for the plasma head
 - IntraMicron provided the sulfur removal system



CERAMATEC
TOMORROW'S CERAMIC SYSTEMS

Uses of Plasma Reformer

- A single technology with multiple uses
 - Oxidize hazardous gases
 - Reform hydrocarbons to produce H_2 and CO
 - Disassociate H_2S to H_2 and S

Hazardous gases oxidation

Hydrocarbon reforming

- Natural gas
- Diesel
- Biomass gasifier residuals
- Other hydrocarbons

Hydrogen sulfide from:

- Natural gas
- Petroleum processing
- Coal gasification

Amine extraction of H_2S

H_2S

Sulfur and H_2

CO_2 and H_2O

H_2 & CO

Fuel Cells
Chemicals
Fuel Synthesis

Non-thermal
Plasma Unit

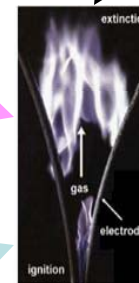

CERAMATEC
TOMORROW'S CERAMIC SYSTEMS

Non-thermal Plasma GlidArc®

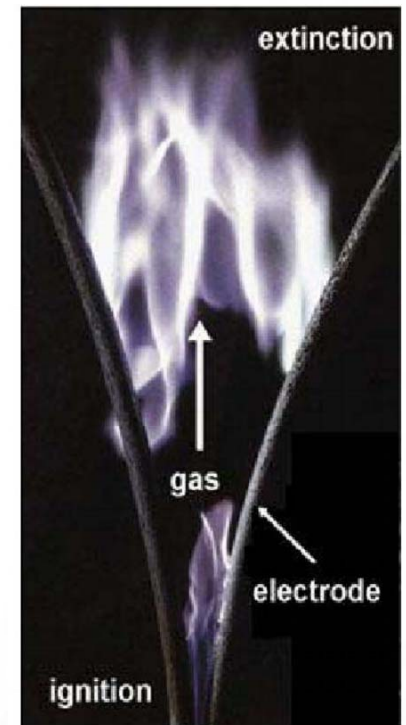
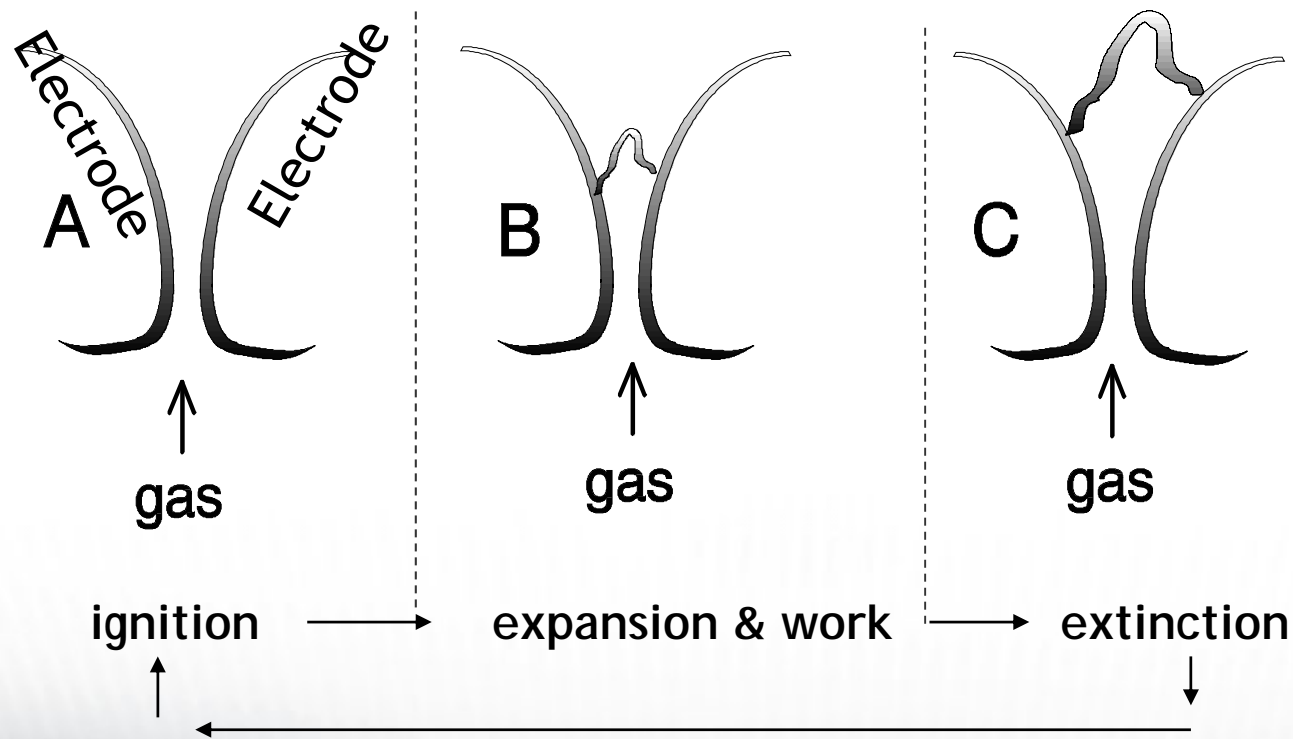

CERAMATEC®
TOMORROW'S CERAMIC SYSTEMS

Obstacles to Use of JP-8

- **Sulfur**
 - Poisons steam reforming catalysts
 - Corrosive effect on system BOP
- **Aromatics, alkenes, alkynes, and alicyclic hydrocarbons**
 - Hydrogen lean mixtures, empirical formula $\text{CH}_{2-\delta}$
 - Prone to soot and coke formation
 - Deactivation of steam reforming catalysts
 - Operational problems to POx, CPOx, ATR, etc.
- **Vaporization**
 - Final Boiling Point near thermal decomposition T



Non-thermal Plasma Reformer Features

- **Plasma operates as a catalyst for reaction**
- **Sulfur insensitive**
 - **No reformation catalyst**
 - **Unaffected by sulfur**
 - **No deactivation over time**
- **Fuel flexibility**
 - **Light to heavy hydrocarbons**
- **Variable operating temperature (set by equilibrium thermodynamics)**
- **Very high reaction zone activity**
 - **Compact reformer size**
 - **Soot free operation**



Equilibrium extent of reformation

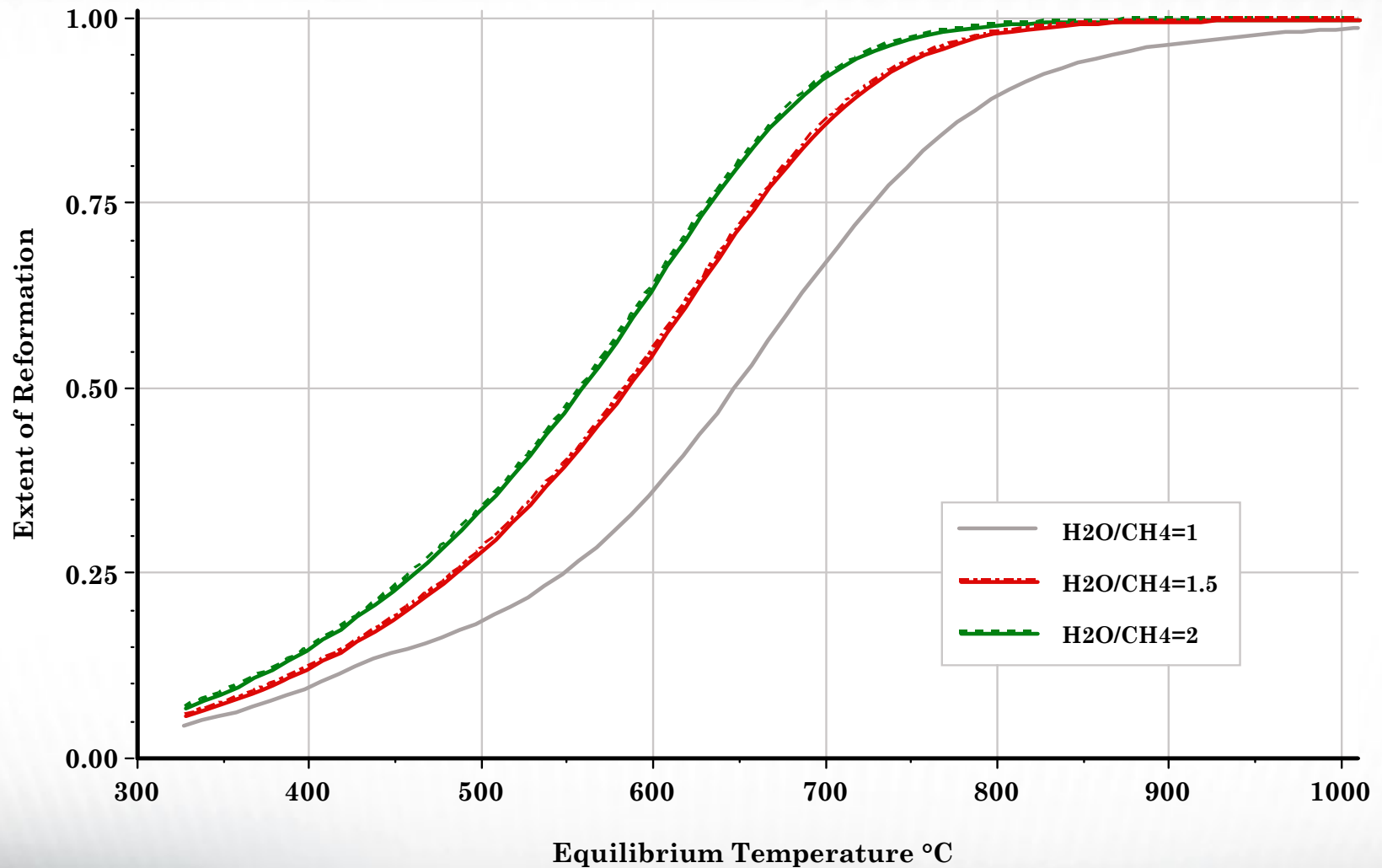

CERAMATEC
TOMORROW'S CERAMIC SYSTEMS

Steam versus POX Reforming

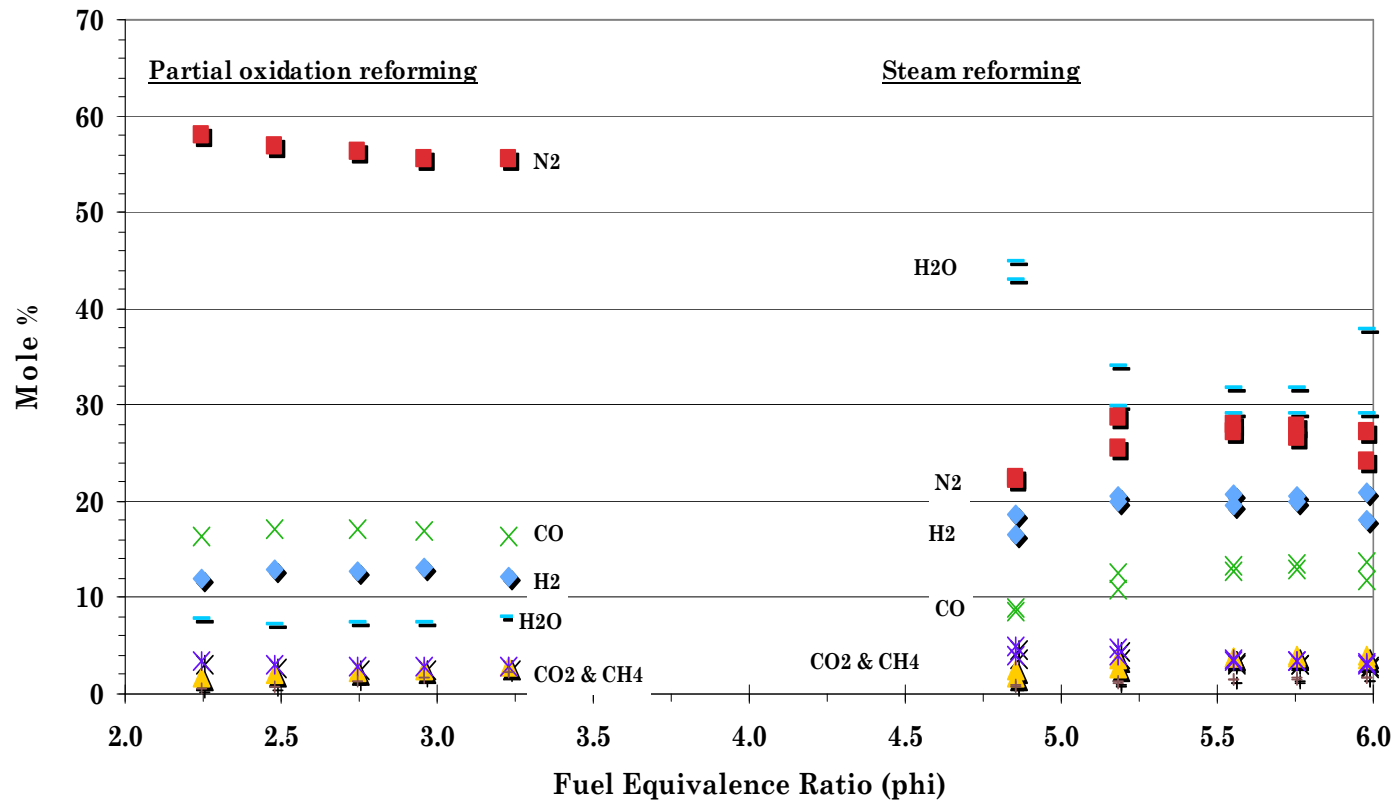

Phi is the inverse stoichiometric ratio of oxygen to fuel, (i.e. a phi of 5 is 20% of the needed oxygen from air – the rest of the oxygen comes from the steam)



CERAMATEC
TOMORROW'S CERAMIC SYSTEMS

Reformate heating value

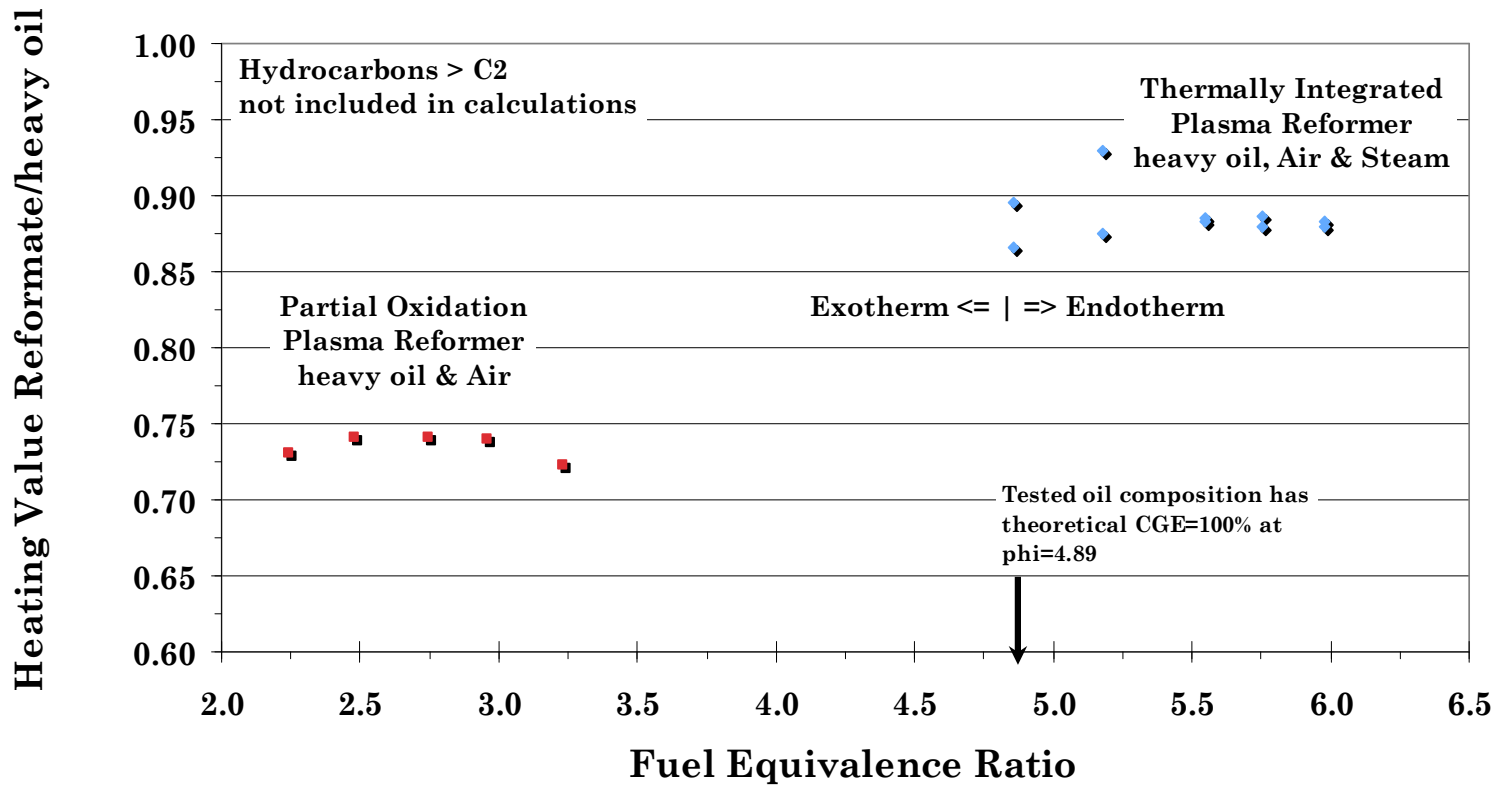

CERAMATEC
TOMORROW'S CERAMIC SYSTEMS

Reformer Mode Case Comparison

- **Standalone (partial oxidation)**
 - 6.07 g/min fuel rate
 - -4.37kW heat rate
 - ~100W plasma power
 - 30 SLPM air flow
 - 2.48 ϕ (fuel equiv. ratio)
 - **1.29 O/C from air**
 - **0 S/C**
 - 32.5% CO + H₂ dry basis
 - 1230W reformer heat loss
 - +671W reforming duty
 - **74.1% Efficiency LHV**
- **Integrated (steam reforming)**
 - 6.35 g/min fuel rate
 - -4.57kW heat rate
 - ~100W plasma power
 - 15 SLPM air flow
 - 5.18 ϕ (fuel equiv. ratio)
 - **0.61 O/C from air**
 - **2.05 S/C**
 - 47.7% CO + H₂ dry basis
 - 81 W reformer heat loss
 - +949W reforming duty
 - **92.9% Efficiency LHV**

LHV = lower heating value



CERAMATEC
TOMORROW'S CERAMIC SYSTEMS

Steam reforming of various fuels

All numbers shown are gas volume percentages and are as recorded by GC

INPUT	H2	O2	>CH4	CH4	CO
JP-8	33-36%	.1-.4%	~.7	3-4%	14-15%
Synthetic	45-46%	.01-.04	.7-1.1%	.6-.8%	18-20%
Synthetic + Naphthalene	44-46%	.03-.1%	~0%	.5-.7%	19-20%
JP-8	12-16%	.6-1%	5-6%	7-8%	14-15%
Synthetic	26-31%	.01-.08%	4-5%	~7%	~18%
Synthetic + Naphthalene	26-30%	.01-.07%	3-4%	~7%	~19%

Blue background is at reformer exit;
Grey background is in reaction zone.



CERAMATEC
TOMORROW'S CERAMIC SYSTEMS

Non-thermal Plasma Reformer Design

- Flexible orientation
- Operates in steam or dry mode
- Catalytic in nature

Design done for TARDEC

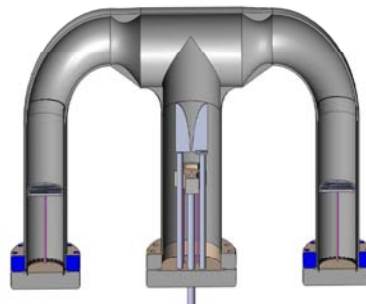

Design done for ONR

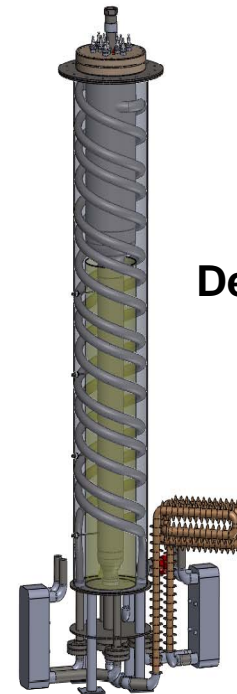

ONR unit in operation

- 60 kWt
- Operates on JP8
- Cold start capable
- Multiple electrodes
- Not designed for mobile application



CERAMATEC
TOMORROW'S CERAMIC SYSTEMS

Electrode array in ONR unit



CERAMATEC
TOMORROW'S CERAMIC SYSTEMS

10 kWe reformer for TARDEC

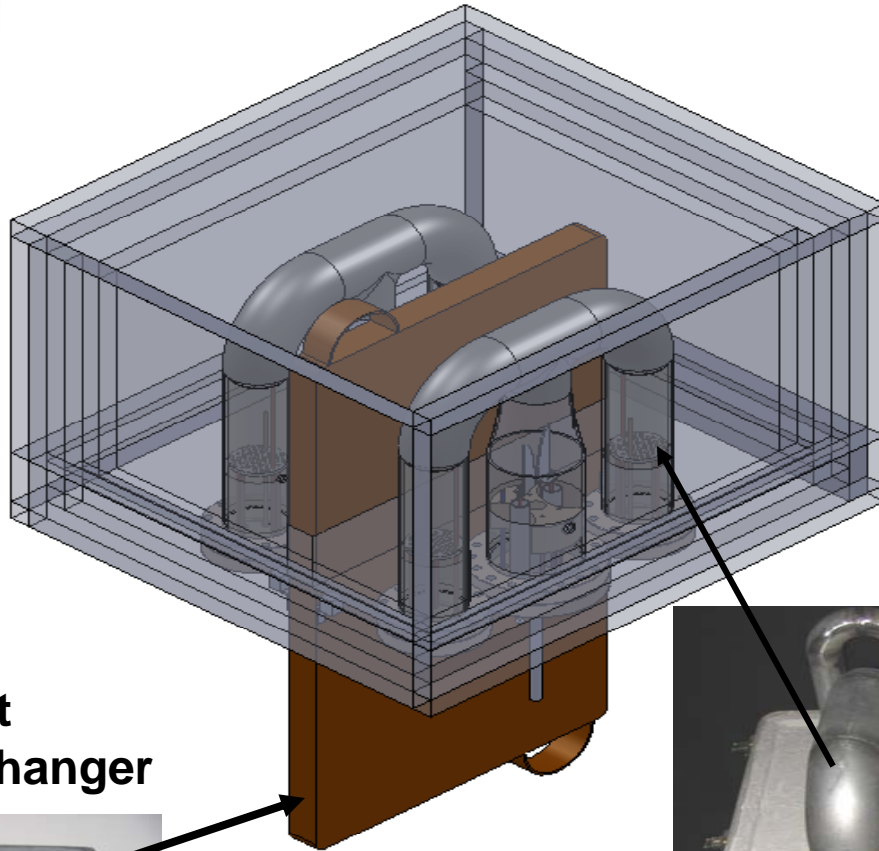

- Plasma reformer
- Sulfur removal
- No fuel cells
- Operates on JP8



Enclosure

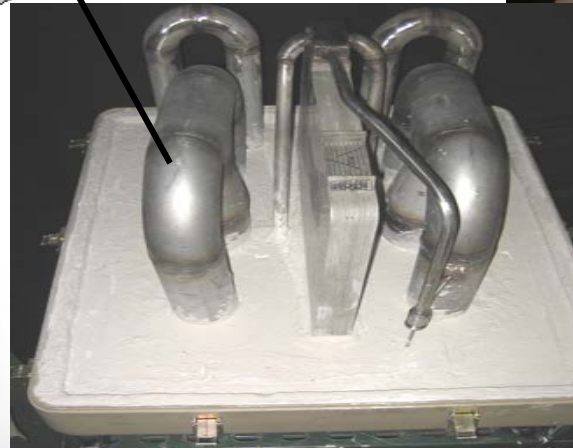

Plasma reformer

Heat Exchanger



CERAMATEC
TOMORROW'S CERAMIC SYSTEMS

Multi-Layer Insulation Design

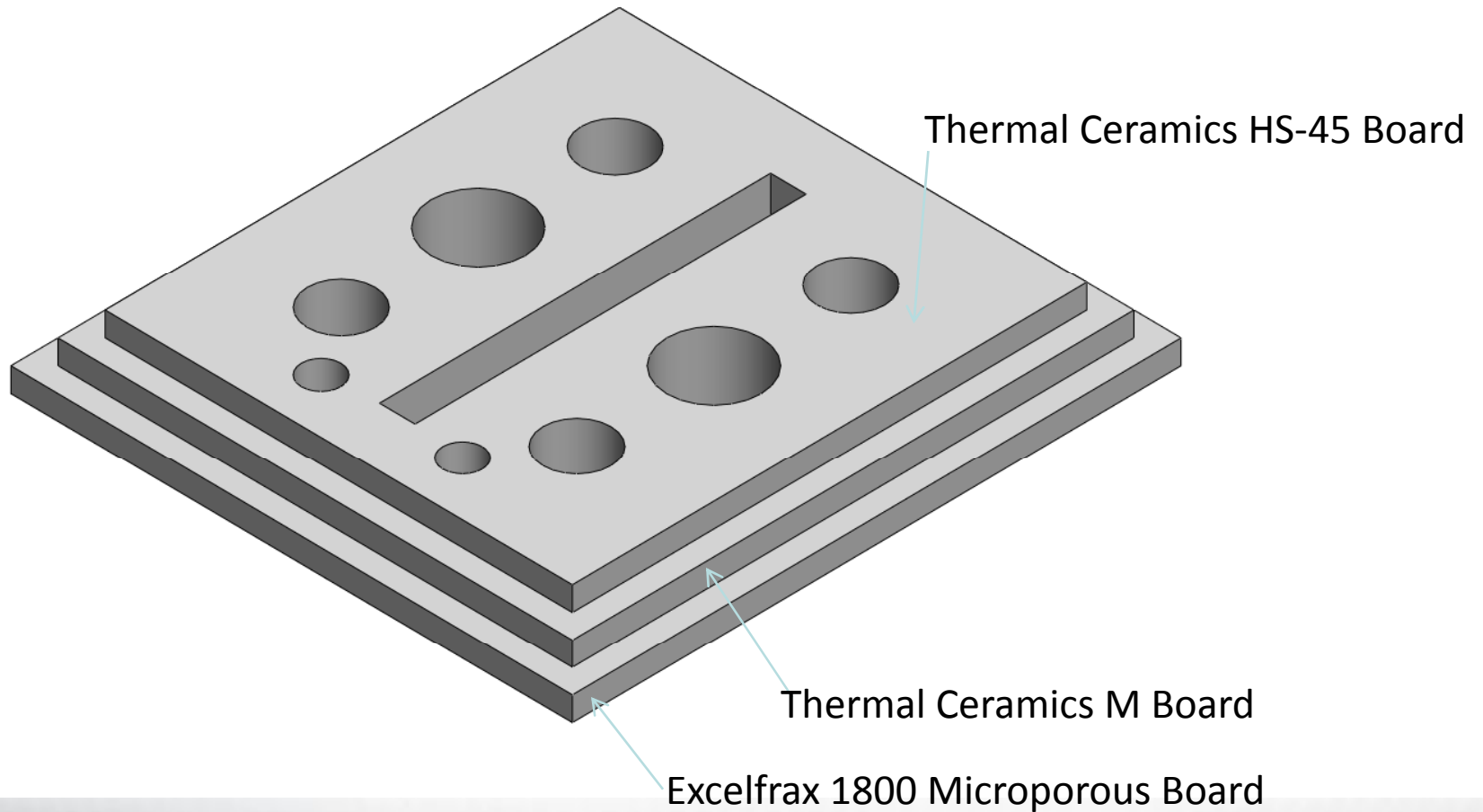

CERAMATEC
TOMORROW'S CERAMIC SYSTEMS

Plasmatron with Reverse Vortex

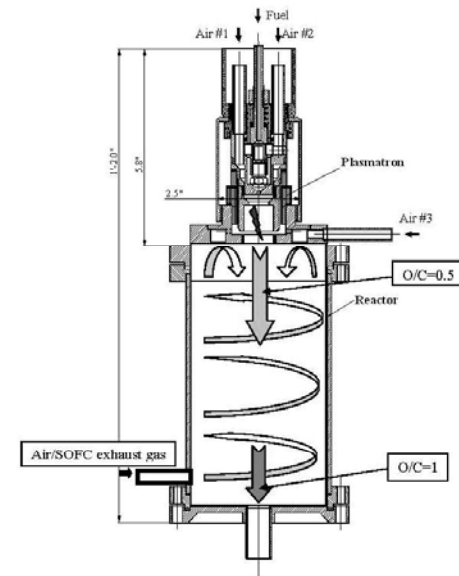
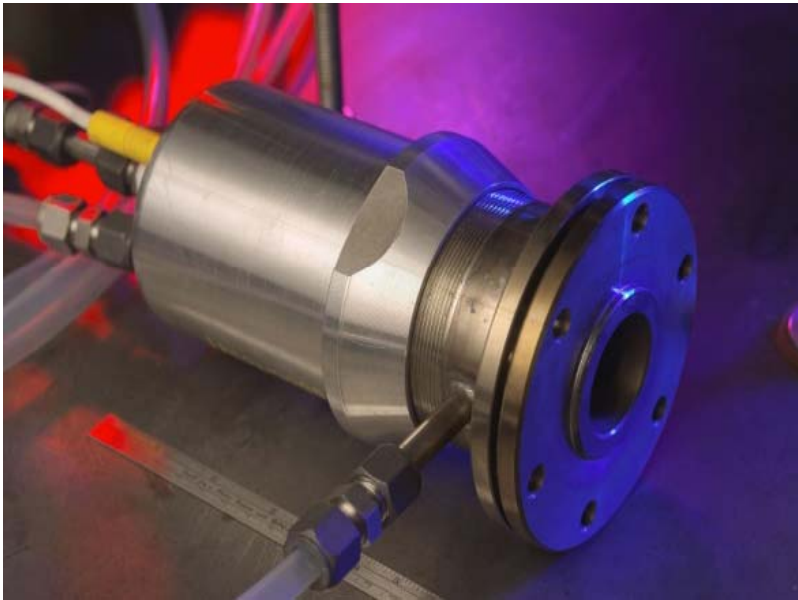

Drexel Plasma Institute is a subcontractor to Ceramatec on this contract



CERAMATEC
TOMORROW'S CERAMIC SYSTEMS

GlidArc® Initial Testing

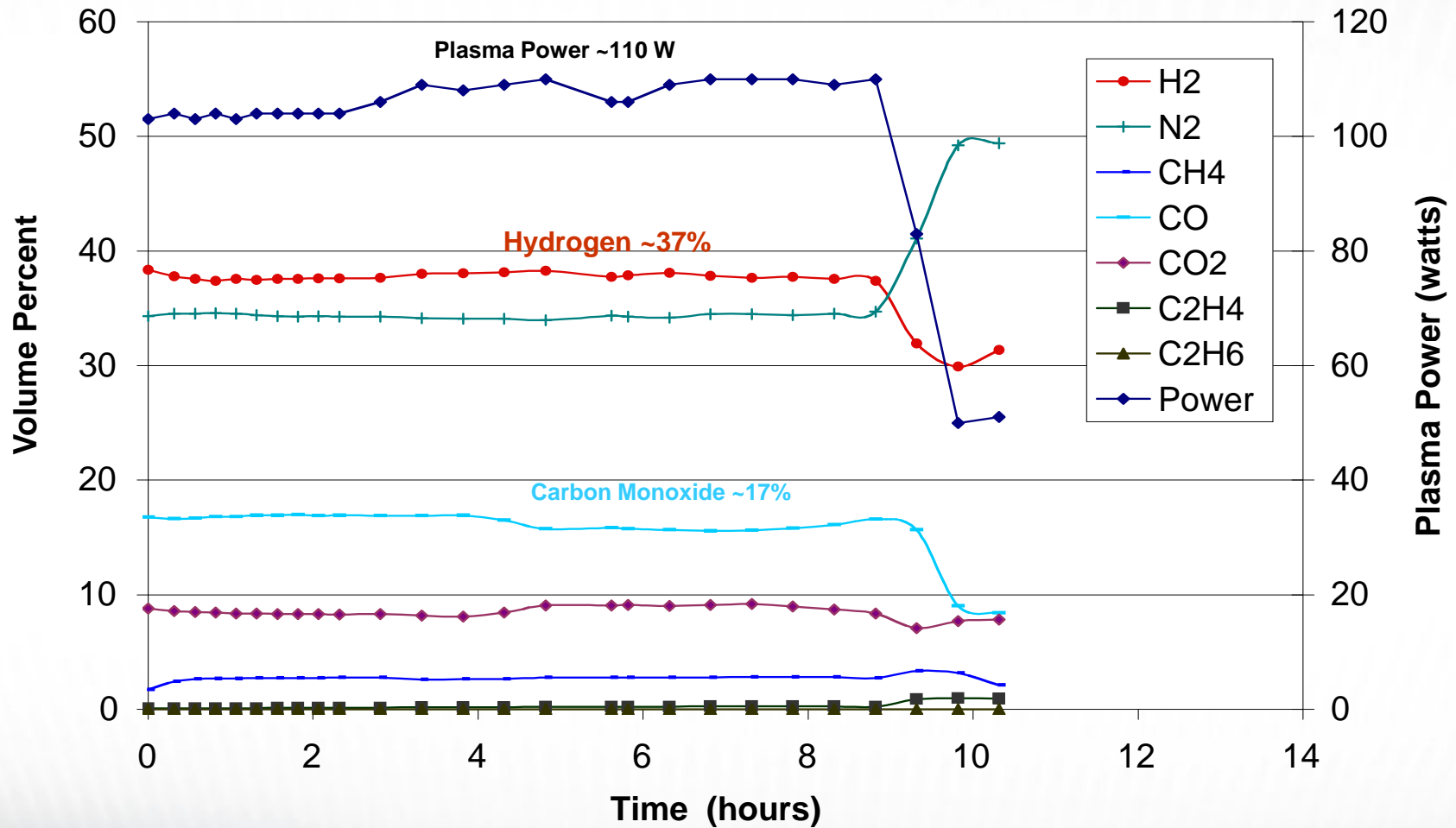

CERAMATEC®
TOMORROW'S CERAMIC SYSTEMS

GlidArc[®] Reformate Composition

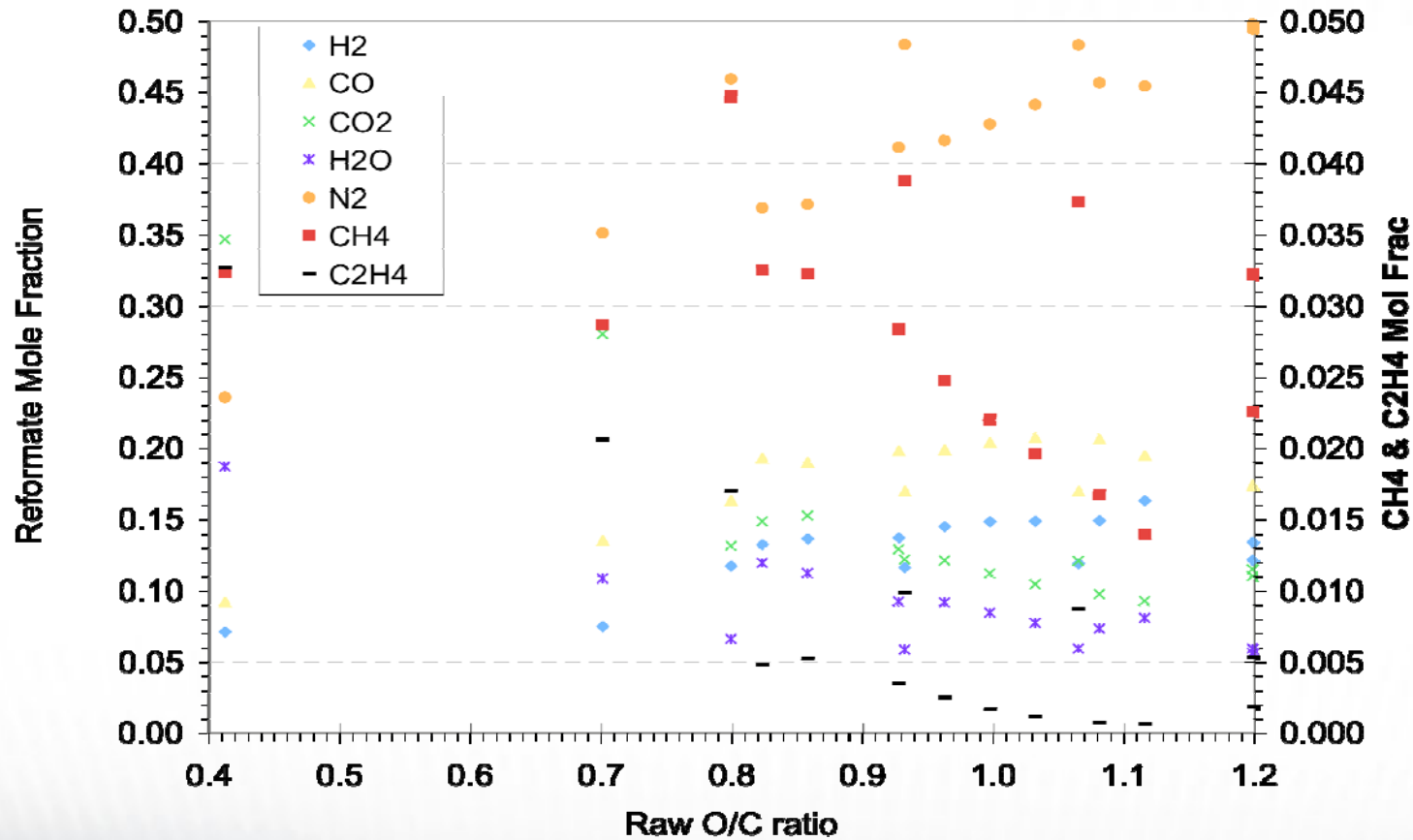

CERAMATEC
TOMORROW'S CERAMIC SYSTEMS

Reformate Composition - Plasmatron

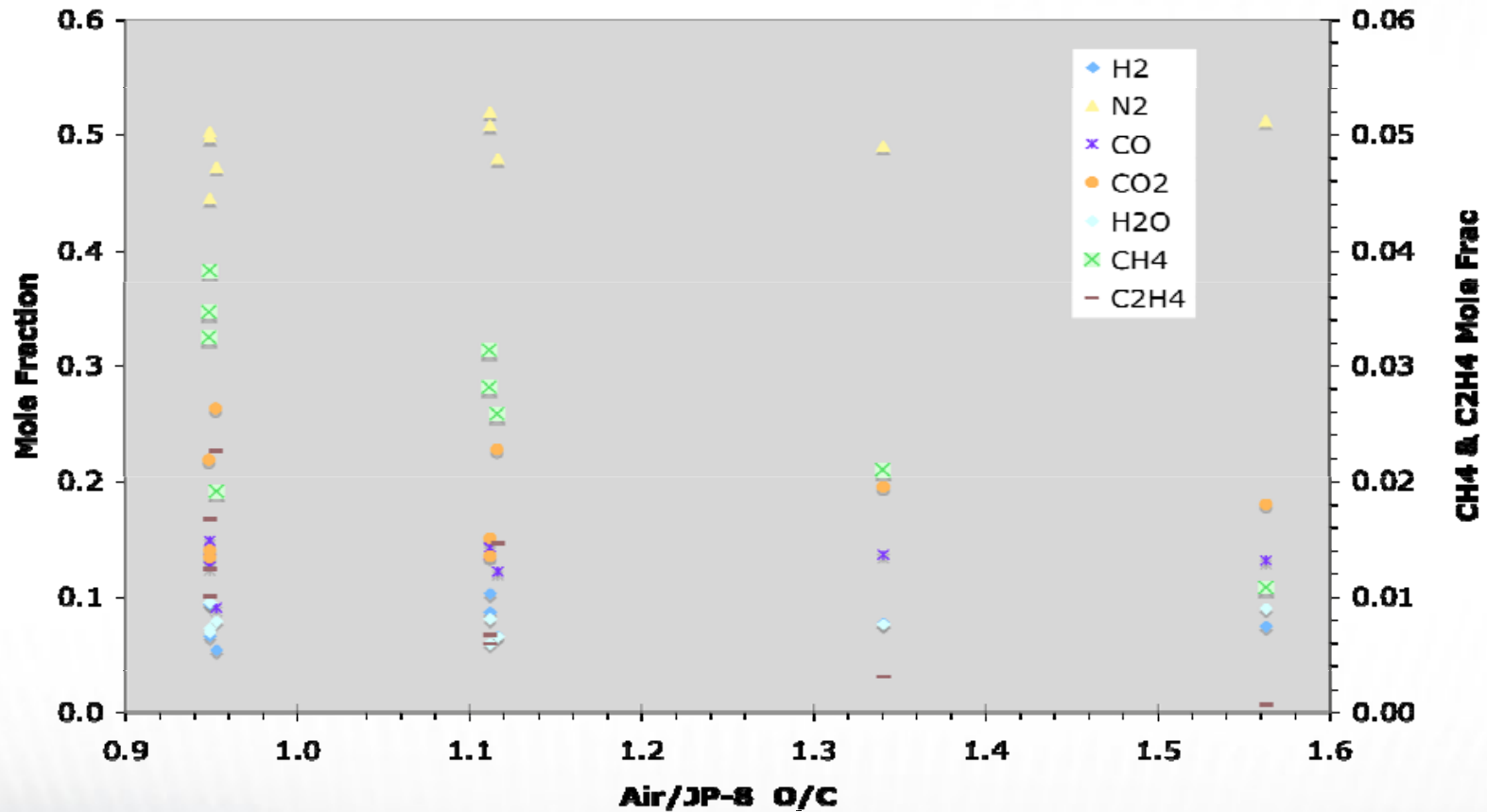

CERAMATEC
TOMORROW'S CERAMIC SYSTEMS

Summary Table of Results

MOLE FRACTION OF REFORMATE

	Plasmatron			GlidArc®		
	1.0 O/C	1.1 O/C	1.3 O/C	1.0 O/C	1.1 O/C	1.2 O/C
H ₂	.10	.10	.08	.15	.16	.14
CO	.12	.13	.13	.20	.20	.18
CO ₂	.20	.18	.19	.12	.10	.12
CH ₄	.03	.03	.02	.02	.02	.02
> CH ₄	.01	.01	.00	.00	.00	.00
N ₂	.47	.49	.50	.43	.45	.49
H ₂ O	.07	.06	.08	.08	.07	.05
TOTAL	~1.00	~1.00	~1.00	~1.00	~1.00	~1.00

Note: Numbers are averaged and rounded



CERAMATEC
TOMORROW'S CERAMIC SYSTEMS

Summary

- **Reformer effective with sulfur laden fuels**
- **Non-thermal plasma operates as a catalyst**
- **Non-thermal plasma means low power**
- **Endothermic steam reforming possible**
- **Plasma unit can be oriented in almost any direction**
- **Results show ability to reform JP-8**
- **Sulfur tolerance of plasma demonstrated**
- **Regenerable sulfur removal system demonstrated**
- **Demonstrates the ability to continuously produce reformat suitable for solid oxide fuel cell**



CERAMATEC
TOMORROW'S CERAMIC SYSTEMS