

A Power Dense 2 kW Logistics Fueled Solid Oxide Fuel Cell System for Mobile Applications

Fuel Cell Seminar
Palm Springs
Nov 16-19 2009

Oral Presentation Session HRD41 SOFC - Fuel Cell Industry II







J. Hawkes¹, K. Centeck², M. Drejer-Jensen³, S. Emerson¹, N. Erikstrup³, T. Hale¹, C. Haugstetter¹, T. Junker¹, A. Kuczek¹, T. Lawton¹, R. Miller⁴, T. Radcliff¹, M. Rottmayer⁴, E. Sun¹, D. Tew¹, E. Wong¹, J. Yamanis¹;

¹United Technologies Res. Ctr., East Hartford, CT, ²TARDEC, Warren, MI, ³Topsoe Fuel Cell, Lyngby, DENMARK, ⁴Air Force Res. Lab., Wright-Patterson AFB, OH.

Objectives

- Phase I – Completed
 - S-8 fueled 1.5kW bench top demonstration
- Phase II – Ongoing
 - Flight test

Team

Organization	Role
	Customer
	Customer
	SOFC System Integrator Reformer
	Stack
	Heat Exchanger
	Exhaust Gas Burner
	Cathode Air Blower

System Flow Sheet

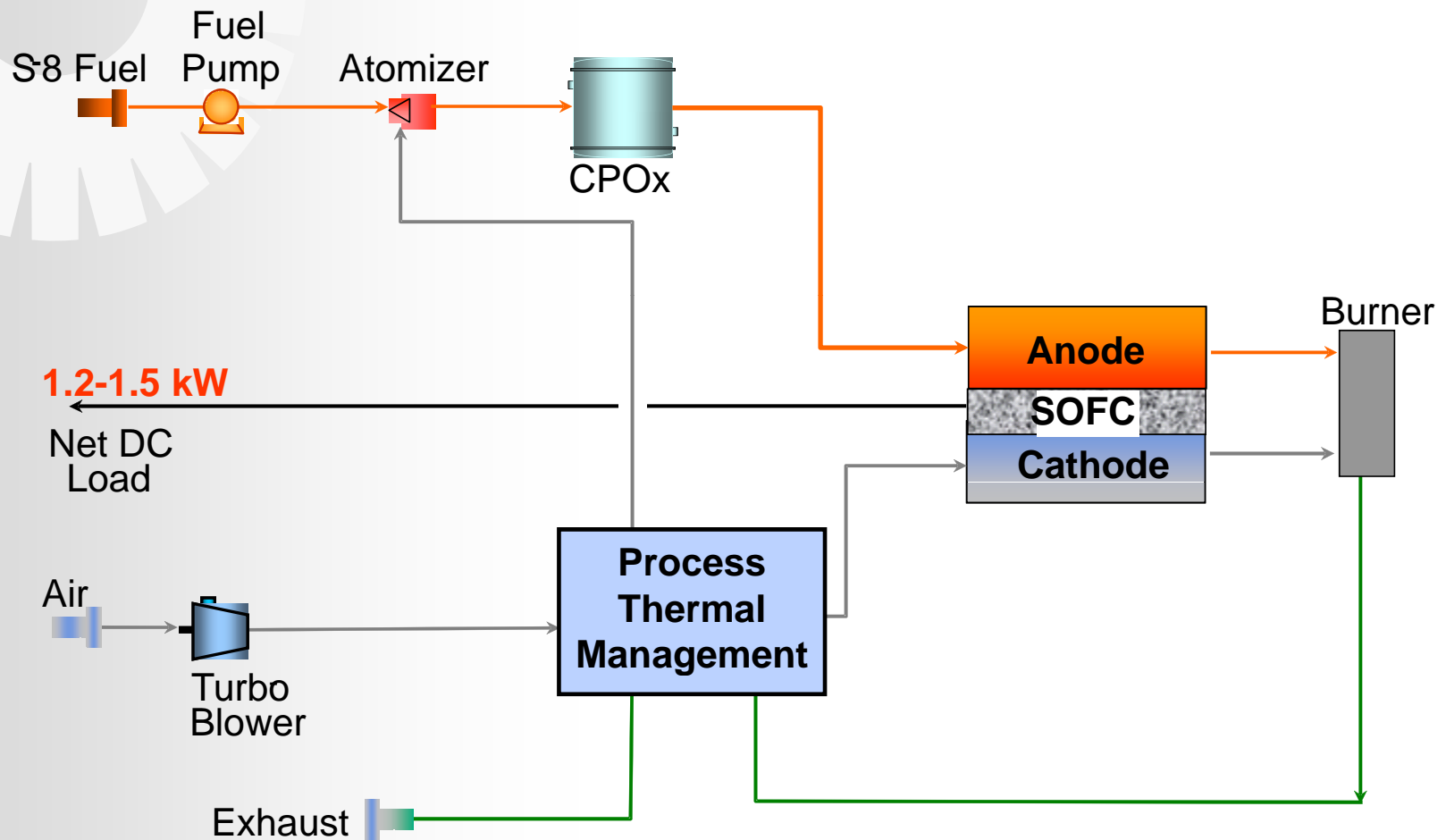

SOFC Flight Value Proposition

Increased Persistence

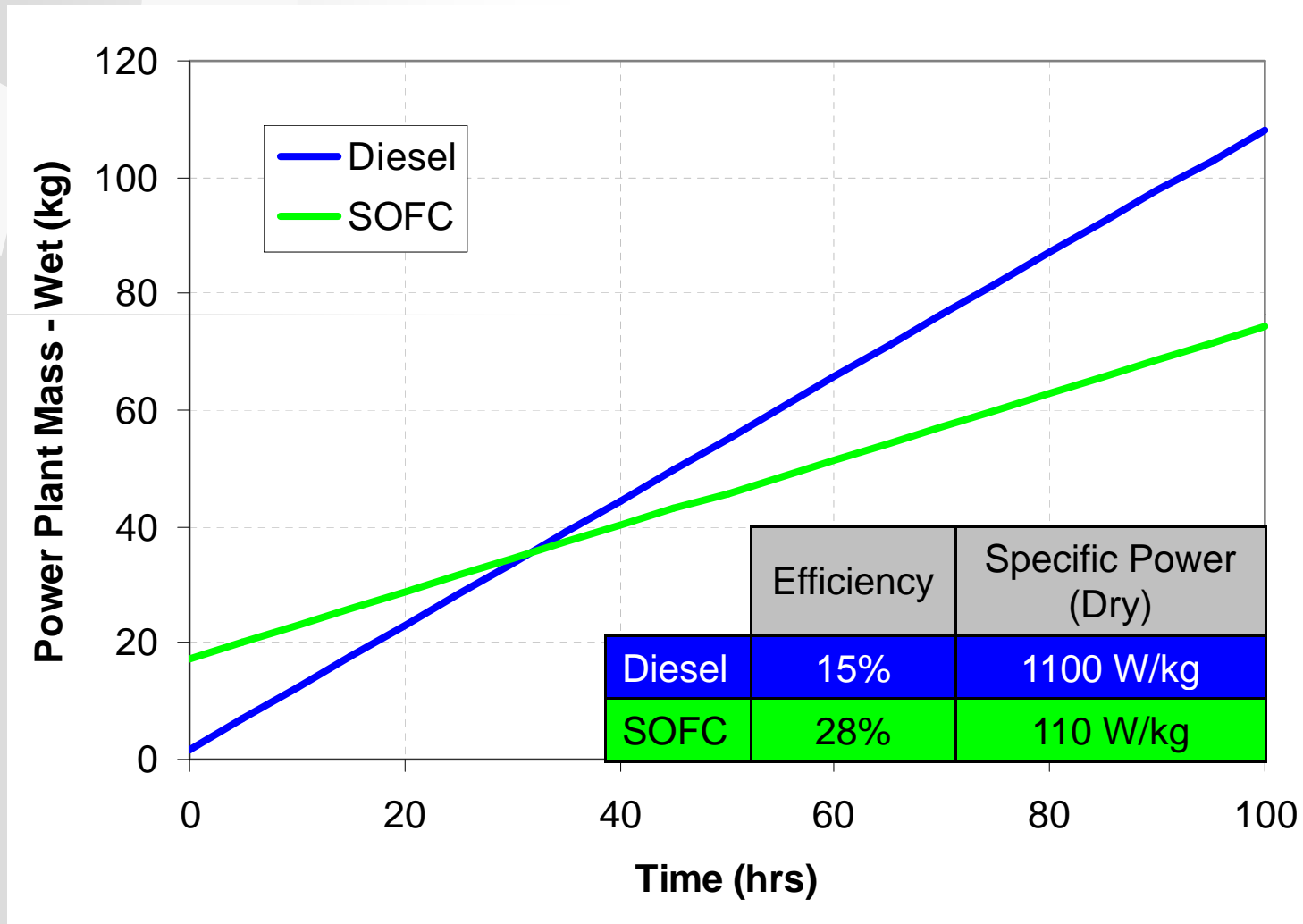

S-8 Fueled Bench Top System

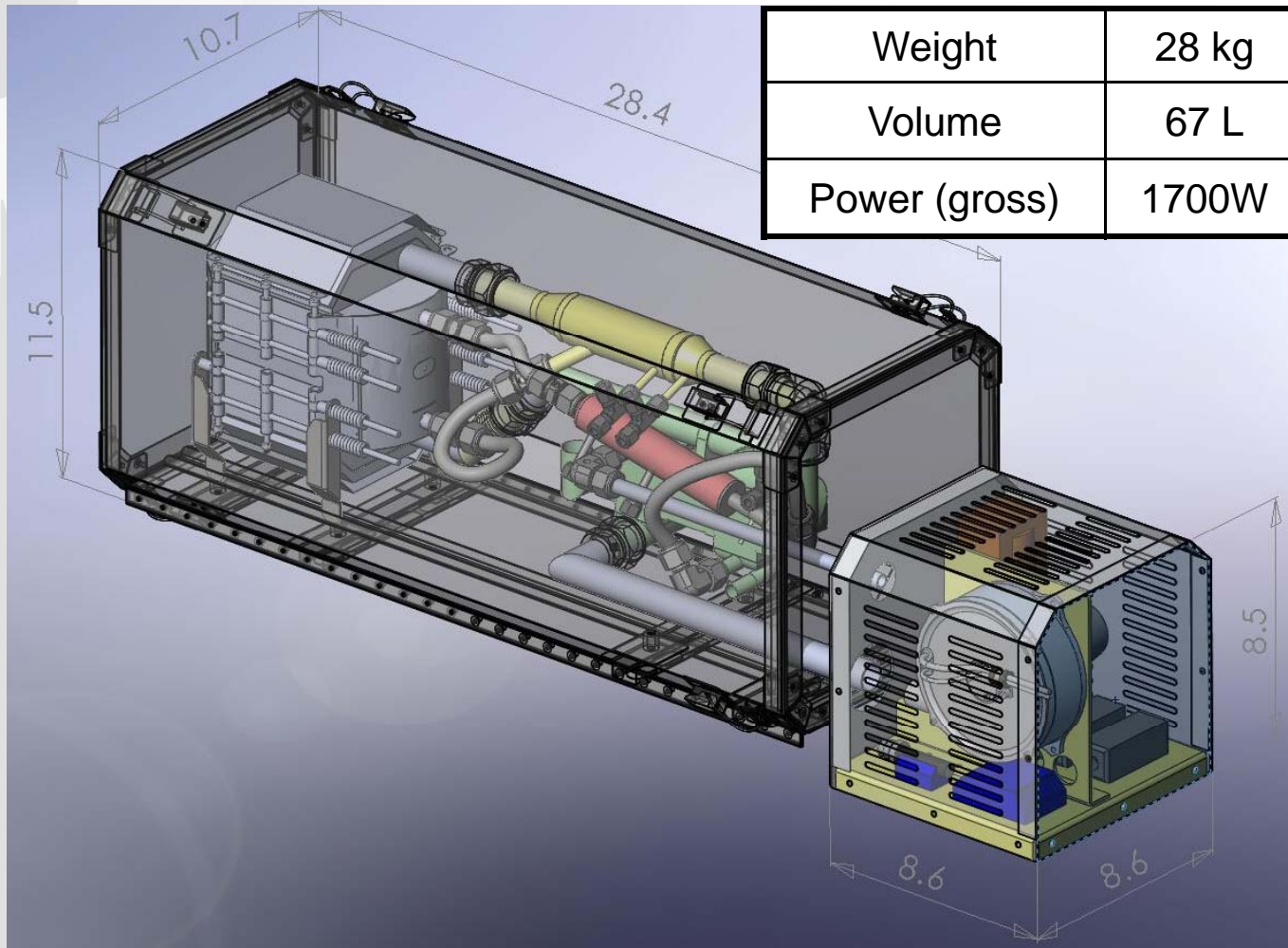

Stack

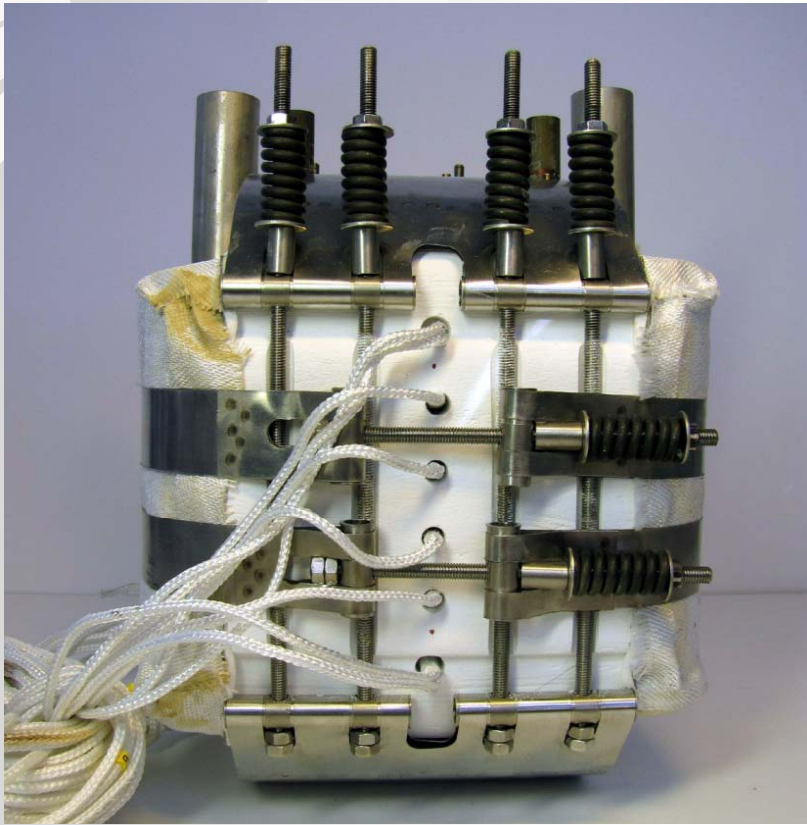

Features

- 2 kW
- Lightweight (9 kg)
- High Specific Power (>200 W/kg)
- Fully Integrated
 - Stack
 - Insulation
 - Compression System
- Large ΔT (>200 °C)

CPOx Reformer

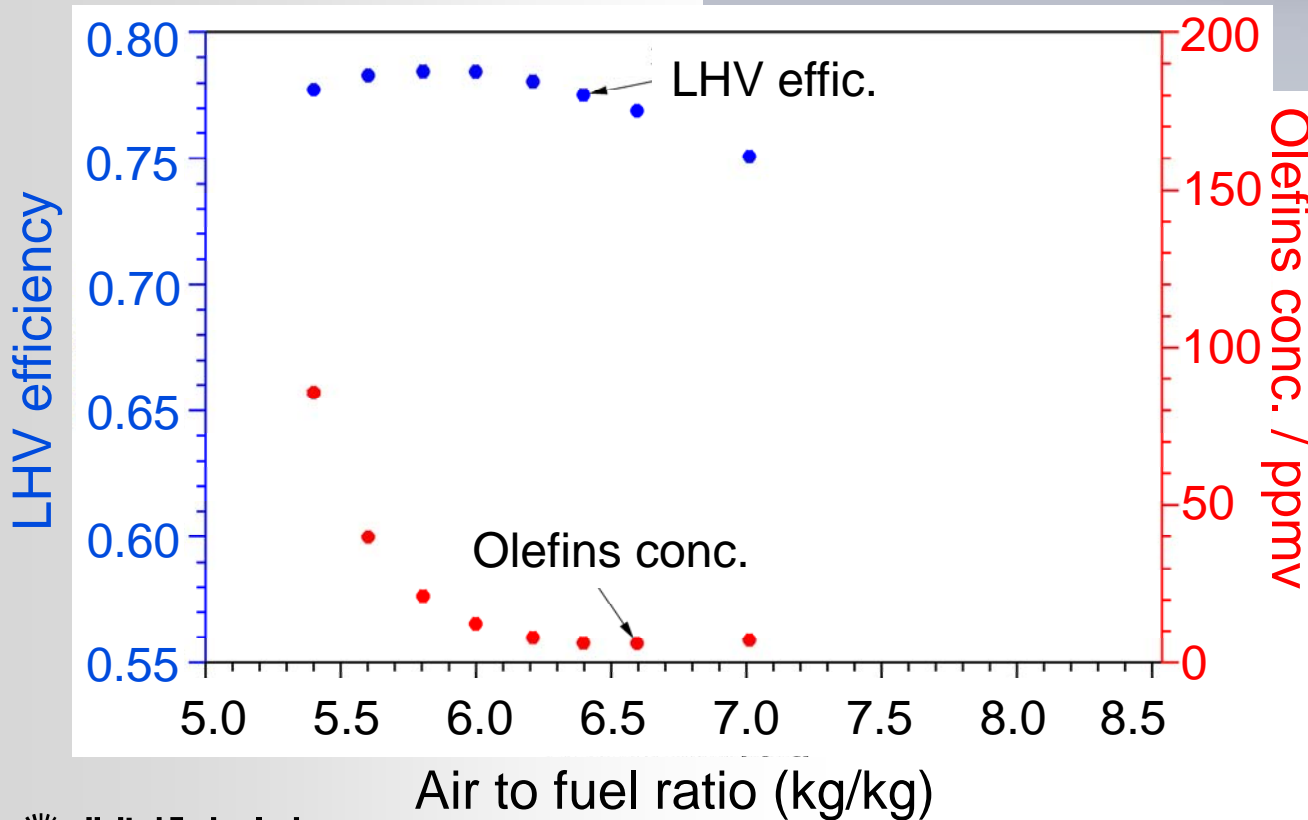
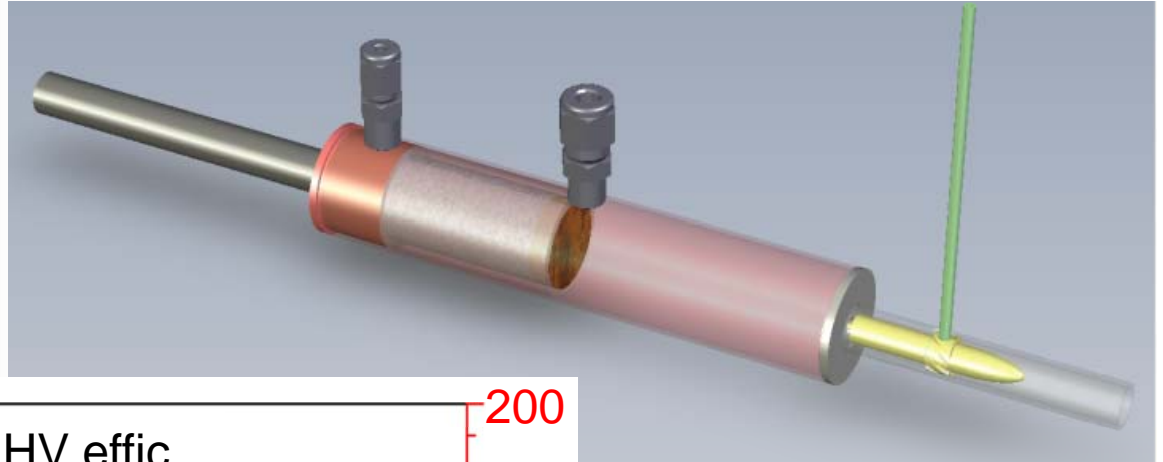

Features

- Compact & lightweight
- Low pressure drop
- Life >300 hr (so far)
- Up to 79% efficiency
- 50% turndown (from nominal, not max.)

High Temperature Heat Exchanger

Features

- High temperature (>900 °C)
- Compact & lightweight
 - 4 streams (3 used)
- Chromium-free oxide
- Effectiveness > 70%



Phase I Bench Top Unit Gross Power versus Time

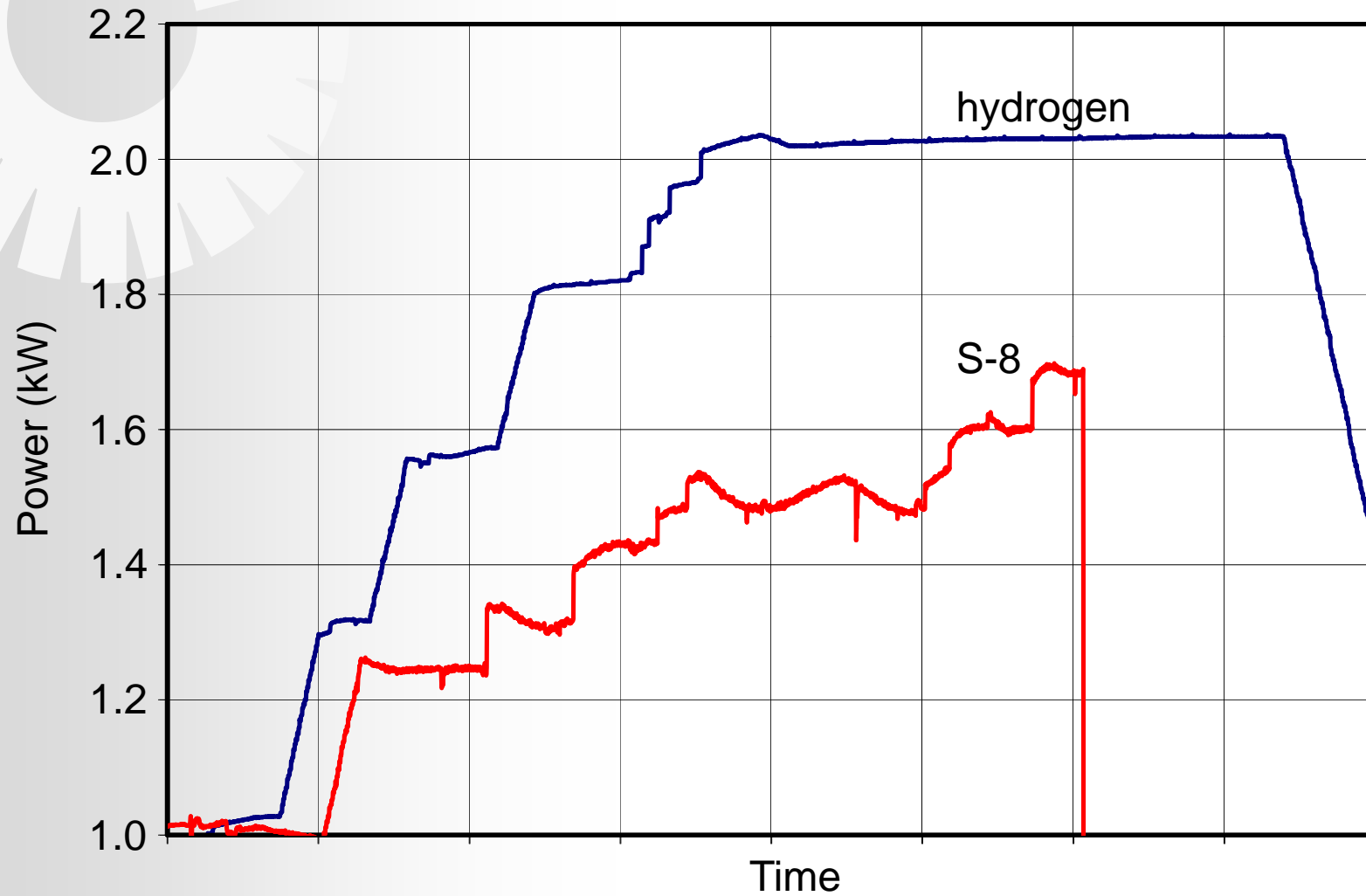

Phase I Bench Top Unit – Shipped to TARDEC



Hex End View

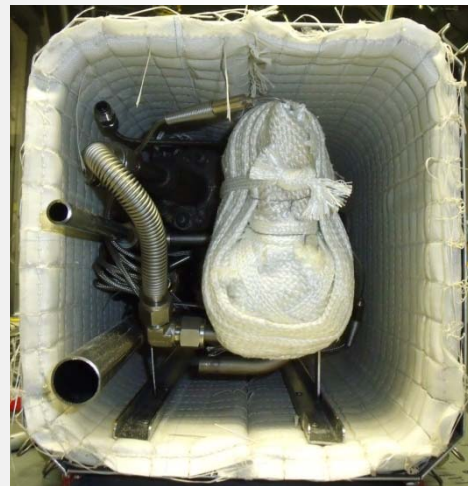

Stack End View



Next Steps

- Flight weight, volume & power bench top unit
- Autonomous control system
 - Push button start/stop
 - Load following
- Flight test