



**INSTITUTE OF HEAT ENGINEERING**  
**WARSAW UNIVERSITY OF TECHNOLOGY**



***Molten Carbonate Fuel Cell Fuelled by Biofuels***

**Jarosław MILEWSKI PhD**  
**Janusz LEWANDOWSKI Full Professor**



# Introduction



## Introduction

Biofuels

MCFC

Results

Discussion

Fuels price inflation

Electricity consumption increase

Efficiency increase

Molten Carbonate Fuel Cell - MCFC

Hybrid Systems: ~250kW



# Introduction



## Introduction

Biofuels

MCFC

Results

Discussion

Currently, the fuel cells are fuelled by:

- hydrogen
- Natural Gas



## Introduction

Biofuels

MCFC

Results

Discussion

## Hydrogen

- not present in the environment in an unconnected form
- difficulties in: production, transportation, and storage

## Natural Gas

- limited resources



# Introduction



**Introduction**

Biofuels

MCFC

Results

Discussion

Future?

1. Electricity instead of fuels
2. „Cultivation” of fuels



## Introduction

Biofuels

MCFC

Results

Discussion

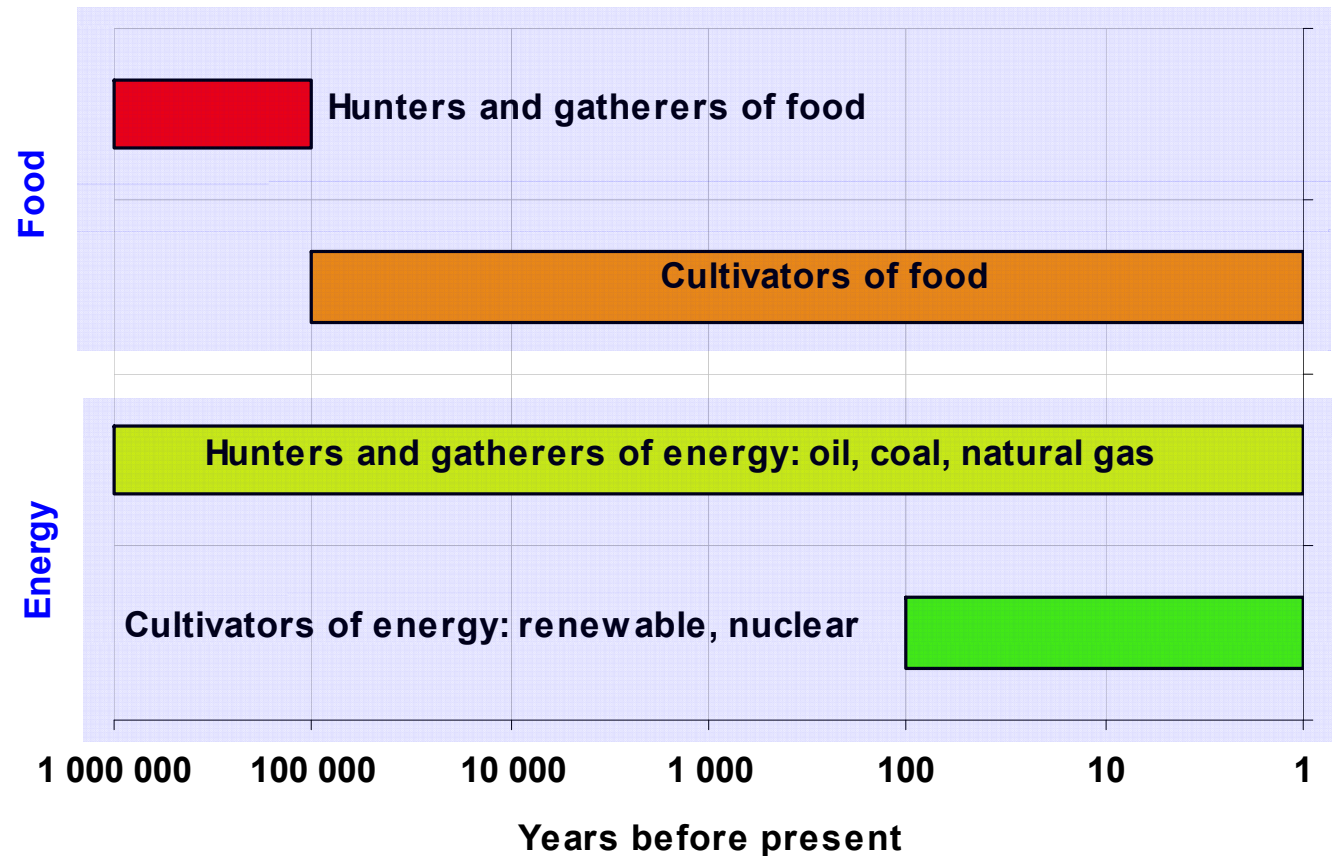



# Biofuels



Introduction

**Biofuels**

MCFC

Results

Discussion

- Gaseous
- Liquid
- Solid
- Others



Introduction

**Biofuels**

MCFC

Results

Discussion

## Natural Gas and Hydrogen as reference fuels

- Anaerobic Digester Gas (ADG)
- Landfill Gas (LFG)
- Bio-Methanol
- Bio-Ethanol
- Canola Oil
- Wood



Introduction

Biofuels

MCFC

Results

Discussion

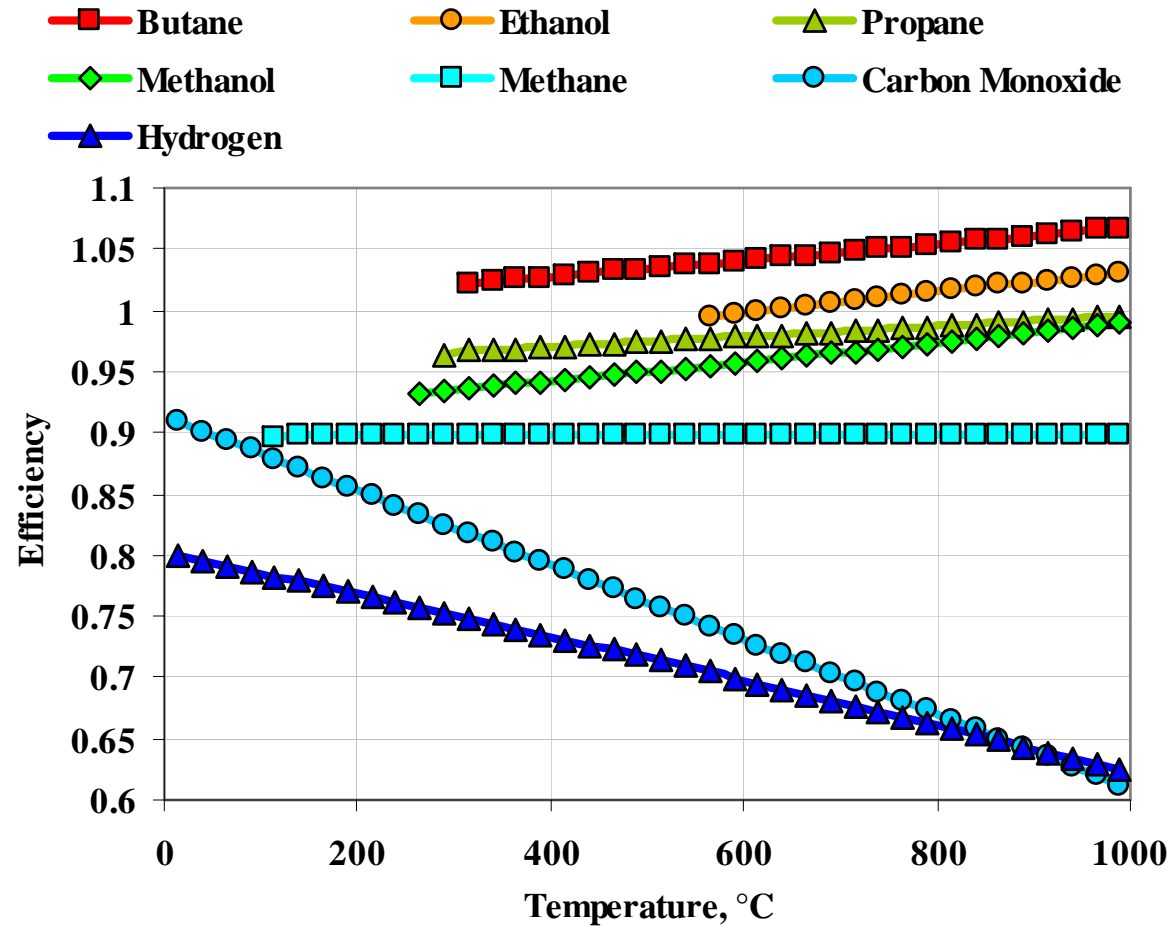

## Introduction

## Biofuels

## MCFC

## Results

## Discussion

$$s/c = \frac{n_{H_2O}}{n_{CH_4} + n_{CO}}$$

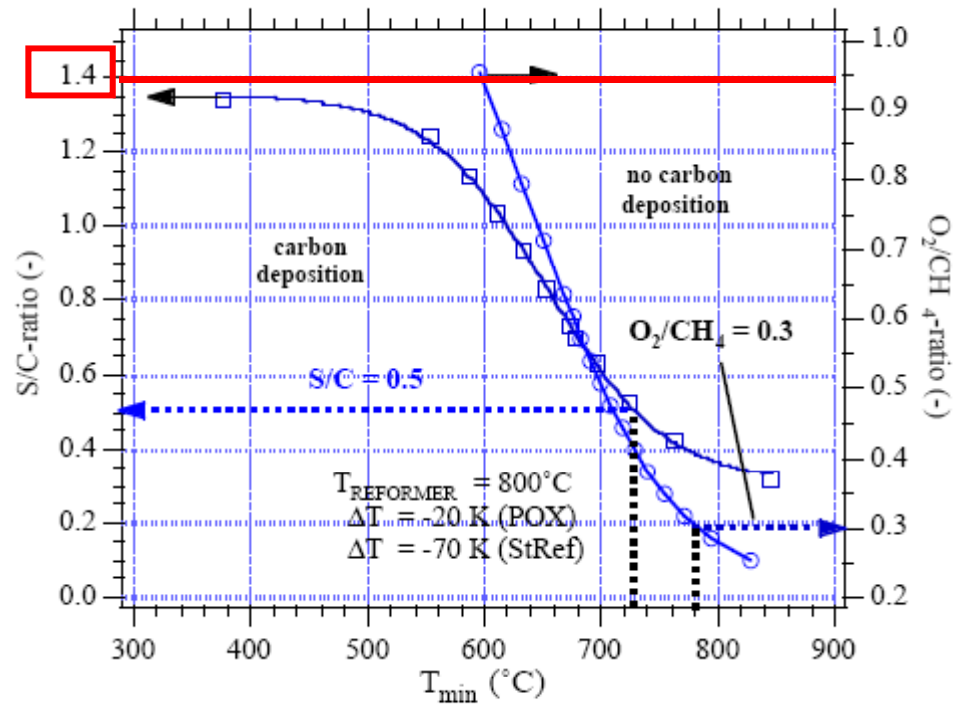



## Introduction

## Biofuels

## MCFC

## Results

## Discussion

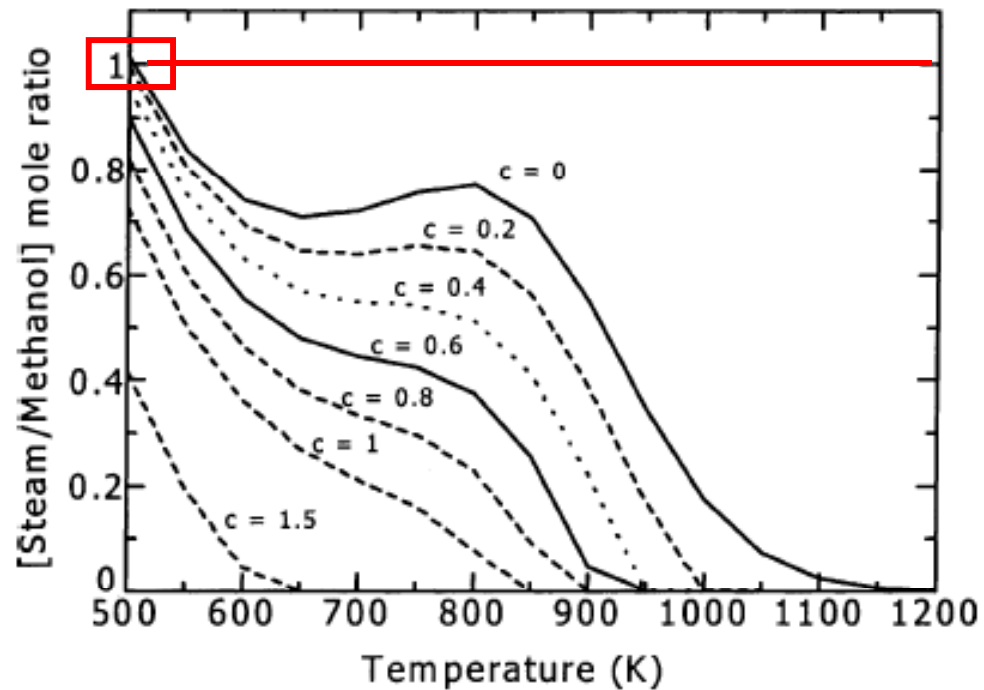



## Introduction

## Biofuels

## MCFC

## Results

## Discussion

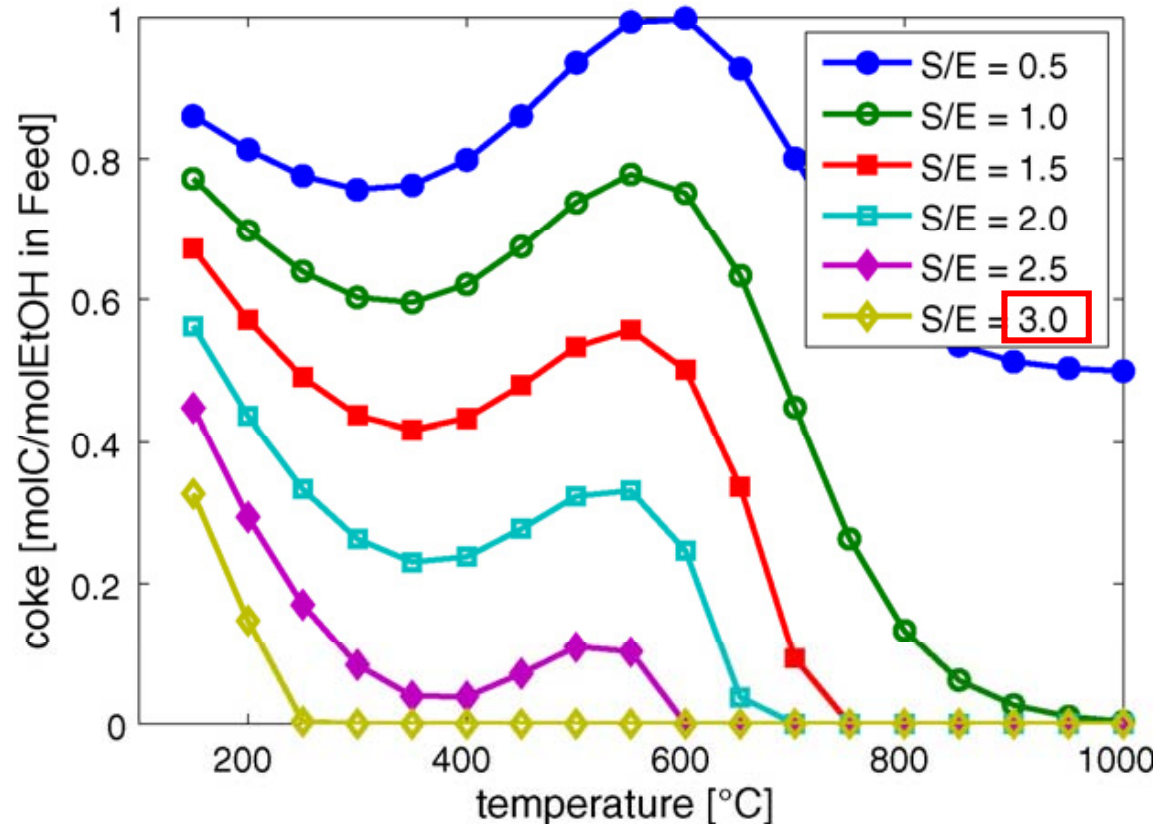

# Maximum voltage for various chemical reactions



Introduction

Biofuels

MCFC

Results

Discussion

Chemical reaction	Maximum voltage
	$E_{\max}$ , V
$H_2 + 1/2 O_2 \rightarrow H_2O$	1.23
$CH_4 + 2 O_2 \rightarrow CO_2 + H_2O$	1.06
$CH_3OH + 3/2 O_2 \rightarrow CO_2 + 2 H_2O$	1.22
$C_2H_5OH + 3 O_2 \rightarrow 2 CO_2 + 3 H_2O$	1.25
$C + O_2 \rightarrow CO_2$	1.03
$C + 1/2 O_2 \rightarrow CO$	0.72
$CO + 1/2 O_2 \rightarrow CO_2$	1.34



## Introduction

## Biofuels

## MCFC

## Results

## Discussion

	ADG	LFG	NG
	%		
CH <sub>4</sub>	62.8	54.0	69.4
CO <sub>2</sub>	35.2	33.0	-
H <sub>2</sub>	-	-	1.39
H <sub>2</sub> O	2.0	13	-
N <sub>2</sub>	-	-	29.21



## Introduction

## Biofuels

## MCFC

## Results

## Discussion

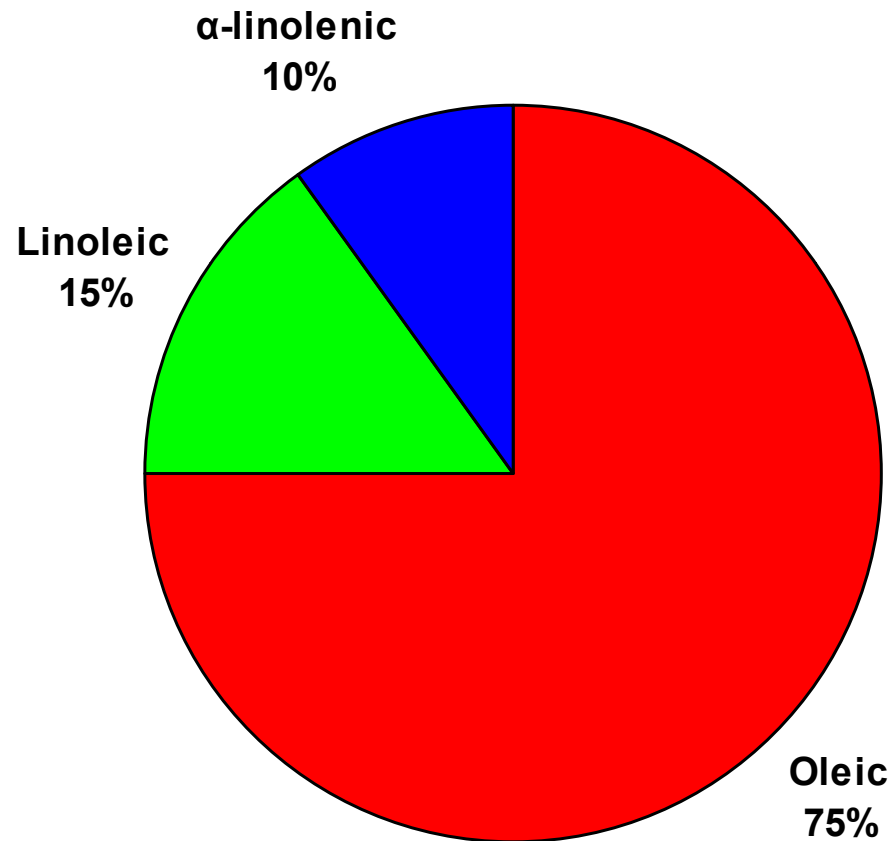



## Introduction

## Biofuels

## MCFC

## Results

## Discussion

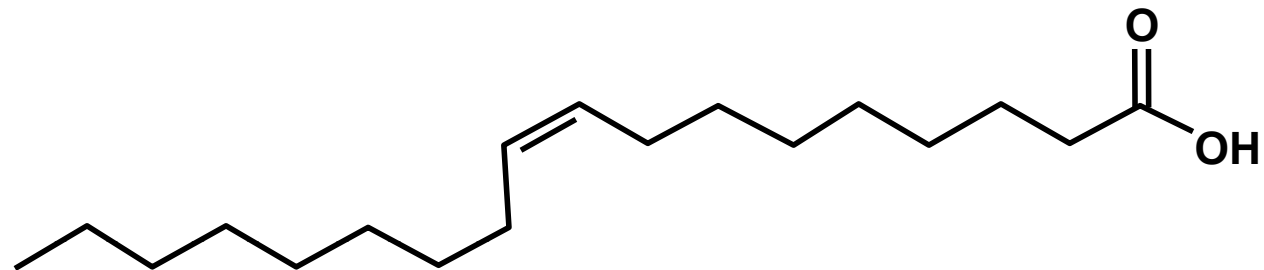

CH <sub>3</sub> -(CH <sub>2</sub> ) <sub>7</sub> -CH=CH-(CH <sub>2</sub> ) <sub>7</sub> -COOH		
Parameter	Real value	Model
Density, kg/m <sup>3</sup>	895	892
Boiling temperature, K	633	487
Heat capacity, kJ/kg	2.1	1.9



## Introduction

## Biofuels

## MCFC

## Results

## Discussion

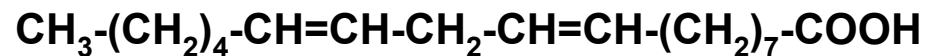
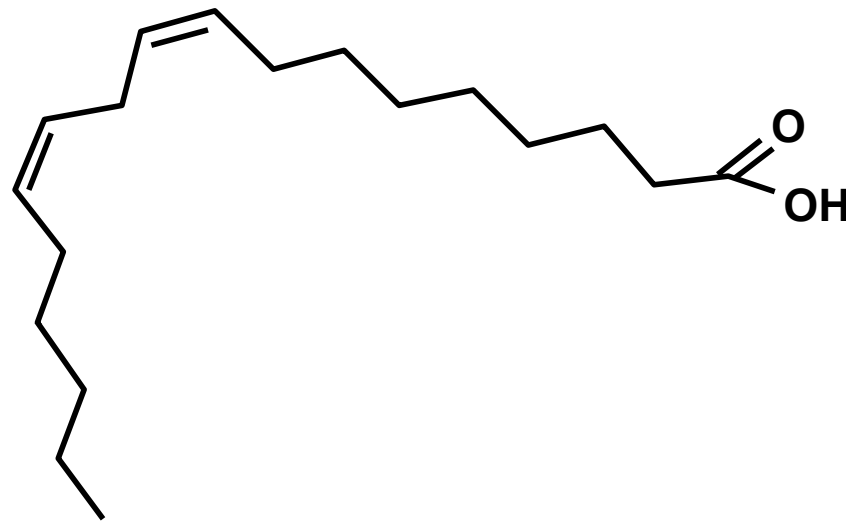

Parameter	Real value	Model
Density, kg/m <sup>3</sup>	902	931
Boiling temperature, K	502	764
Heat capacity, kJ/kg	-	1.9



## Introduction

## Biofuels

## MCFC

## Results

## Discussion



$\text{CH}_3\text{-CH}_2\text{-CH=CH-CH}_2\text{-CH=CH-CH}_2\text{-CH=CH-(CH}_2\text{)}_7\text{-COOH}$		
Parameter	Real value	Model
Boiling temperature, K (4mmHg)	184	281
Heat capacity, kJ/kg	-	1.9
Density, kg/m <sup>3</sup>	916	907



Introduction

Biofuels

MCFC

Results

Discussion

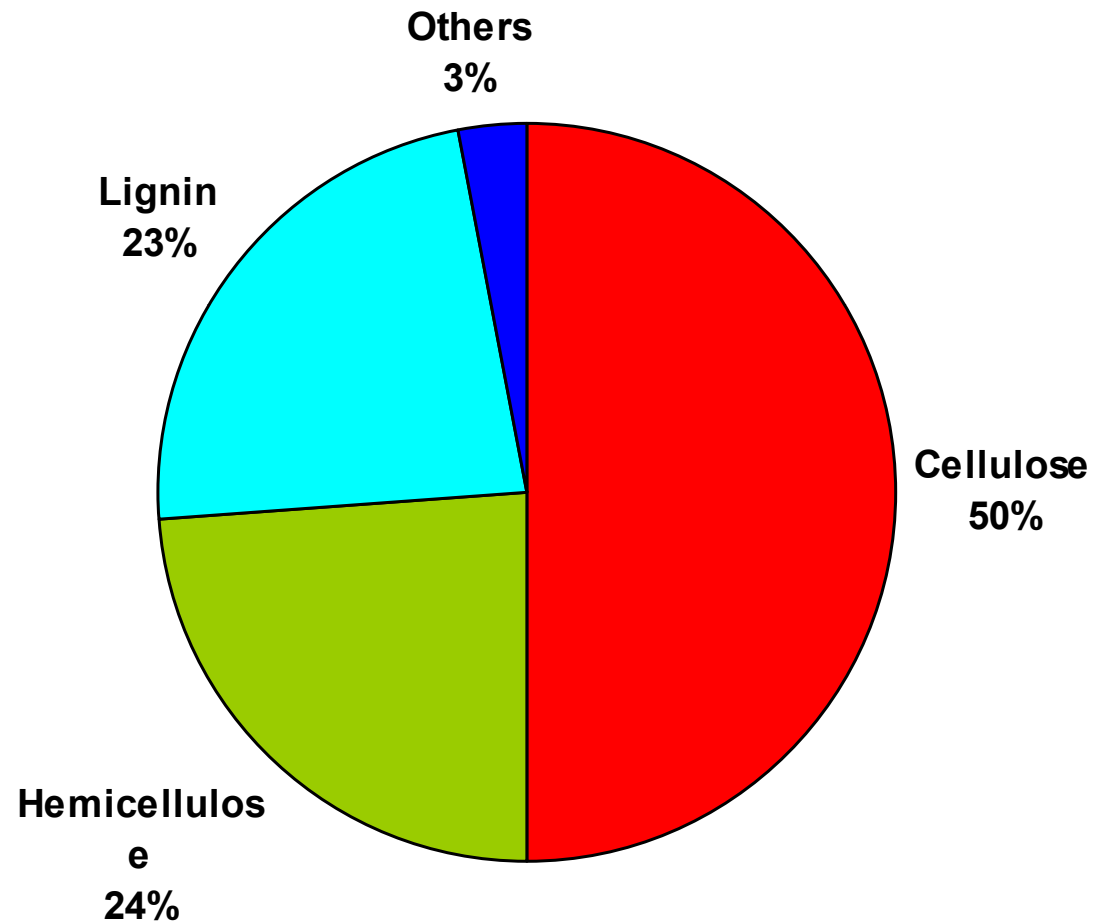



## Introduction

## Biofuels

## MCFC

## Results

## Discussion

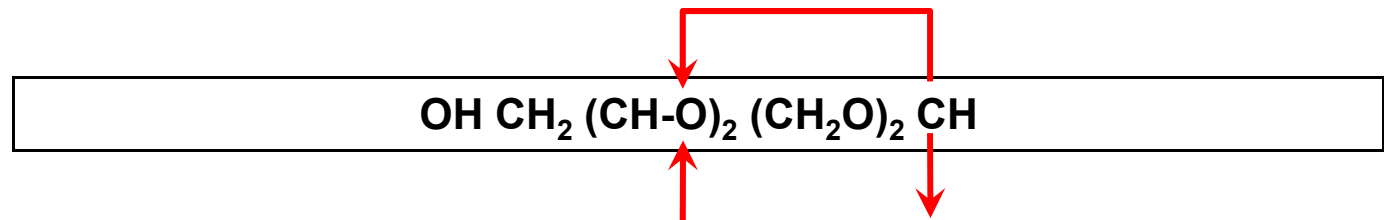
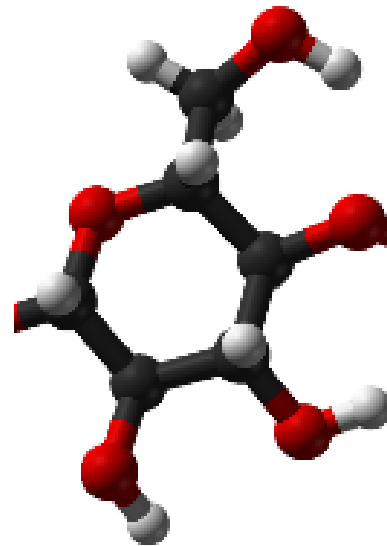



## Introduction

## Biofuels

## MCFC

## Results

## Discussion

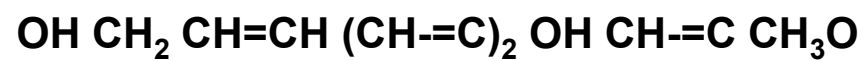
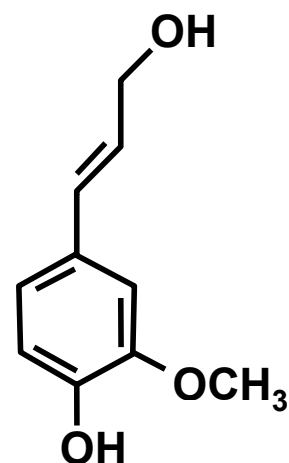



Introduction

Biofuels

**MCFC**

Results

Discussion

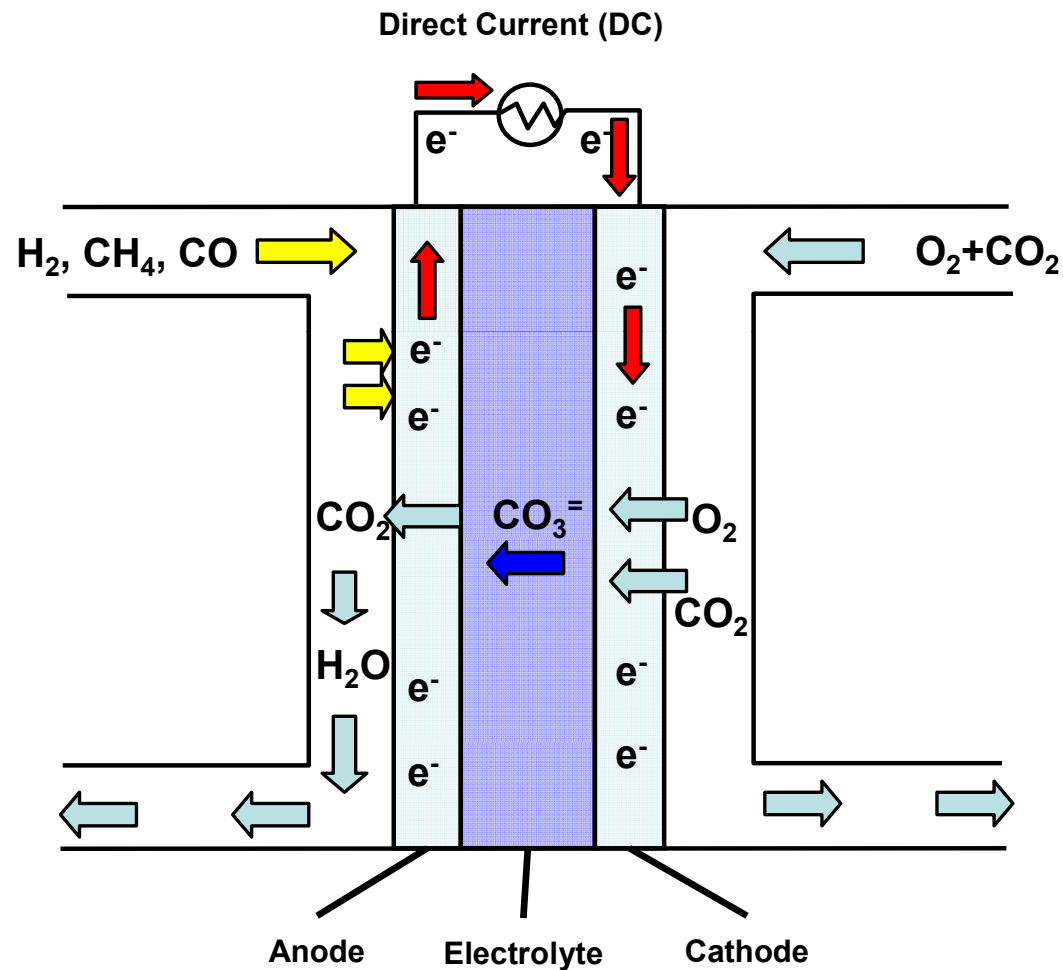



Introduction

Biofuels

**MCFC**

Results

Discussion

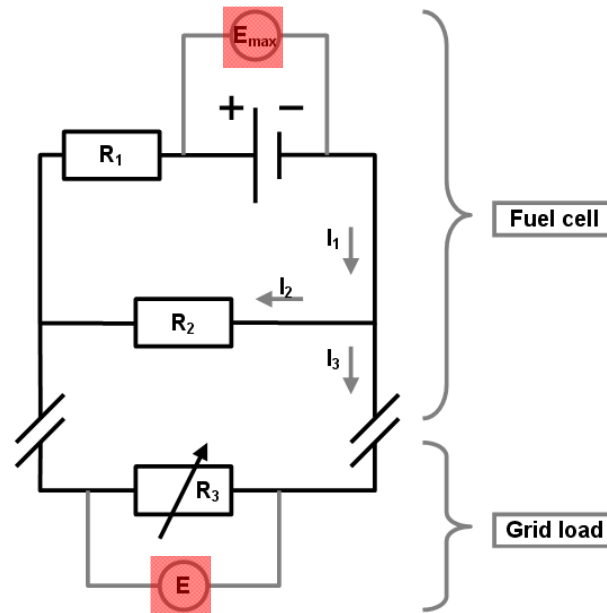

$$E_{MCFC} = \frac{E_{\max} - \eta_f \cdot i_{\max} \cdot r_1}{\frac{r_1}{r_2} \cdot (1 - \eta_f) + 1}$$

$$E_{\max} = \frac{RT}{4F} \ln \frac{p_{O_2, cathode} \cdot p_{CO_2, cathode}^2}{p_{O_2, anode} \cdot p_{CO_2, anode}^2}$$



Introduction

Biofuels

MCFC

Results

Discussion

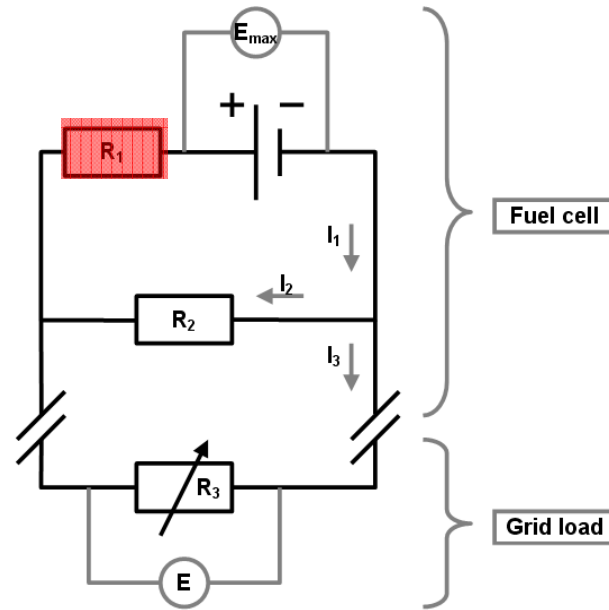

$$r_1 = \frac{\delta}{\sigma}$$

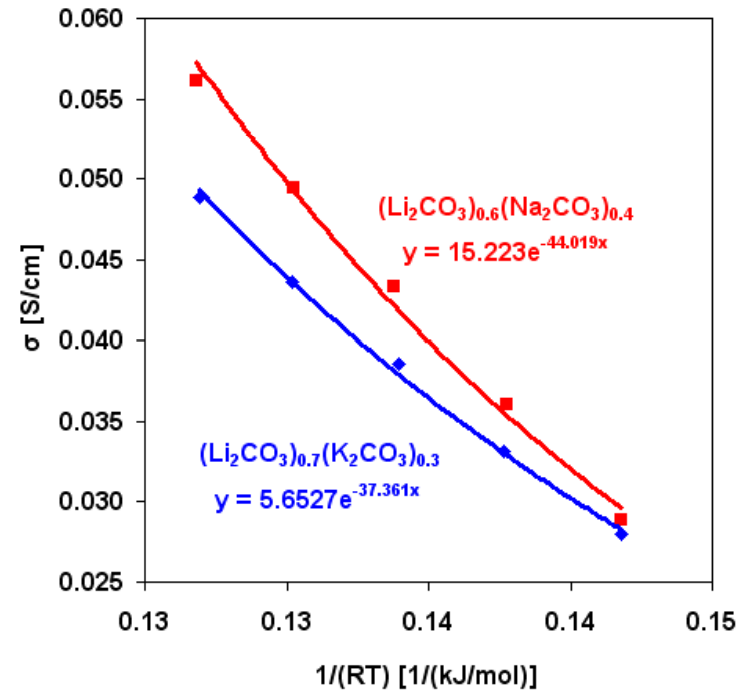

$$\sigma = \sigma_0 \cdot e^{\frac{-E}{RT}}$$



Introduction

Biofuels

**MCFC**

Results

Discussion

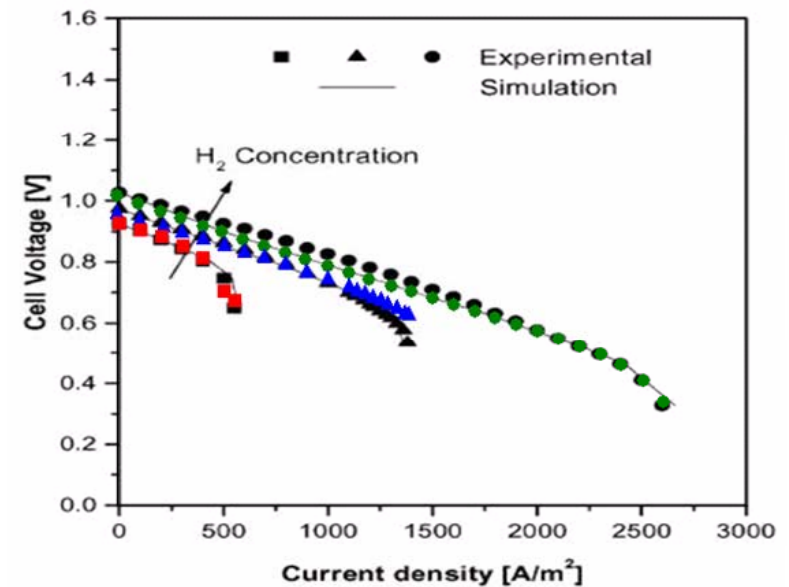
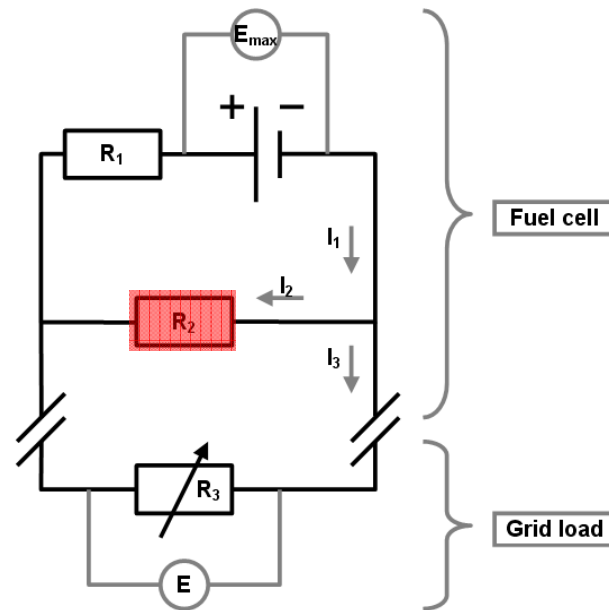

$$r_2 = 28 \Omega cm^2$$



Introduction

Biofuels

MCFC

Results

Discussion

- 0D, design point (chemical equilibrium)
- $i_{\max} = \text{constant}$
- pressure: 1bar
- MCFC temperature: 650°C
- electrolyte type: Li/Na
- matrix thickness: 1mm



## Introduction

## Biofuels

## MCFC

## Results

## Discussion

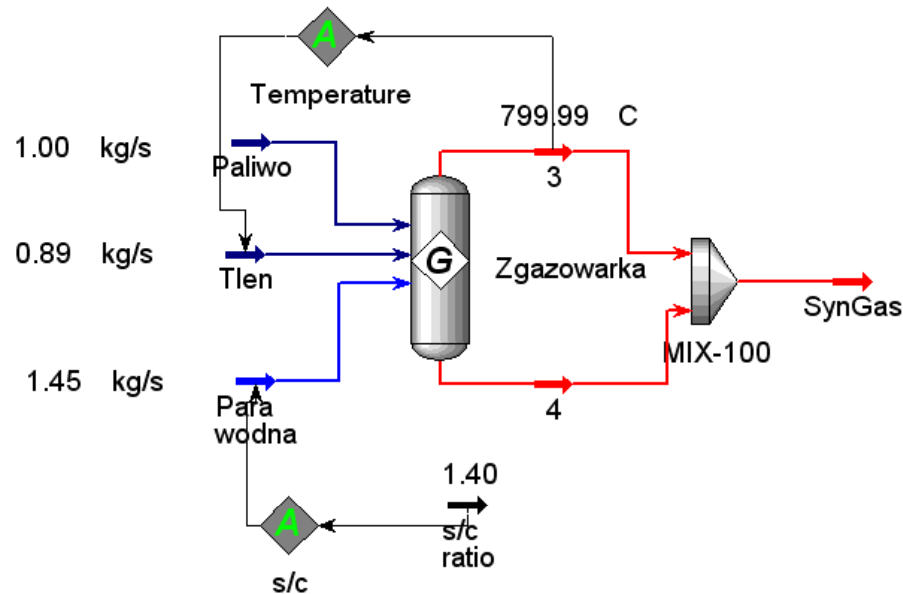

SynGas		
Temperature	799.99	C
Pressure	1.000	bar
Mass Flow	3.34	kg/s
Hydrogen	0.0520	
H2O	0.2888	
Nitrogen	0.0000	
Oxygen	0.0000	
Methane	0.0004	
CO	0.3201	
CO2	0.1263	
Ethanol	0.0000	
Methanol	0.0000	
Ethane	0.0000	
Propane	0.0000	
Butane	0.0000	
Oleinowy	0.0000	
Linolowy	0.0000	
Linolenowy	0.0000	



Introduction

Biofuels

MCFC

Results

Discussion

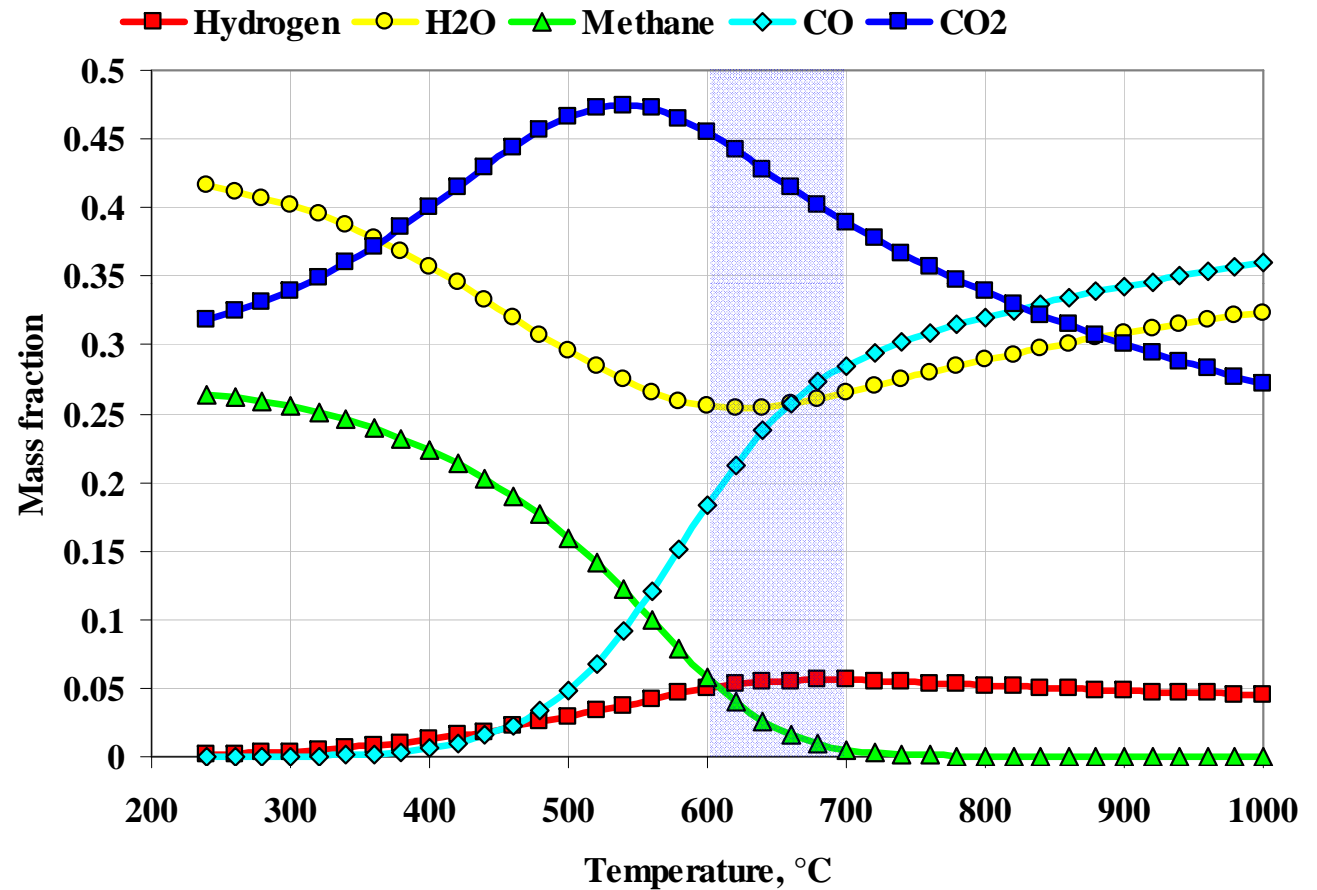



Introduction

Biofuels

MCFC

Results

Discussion

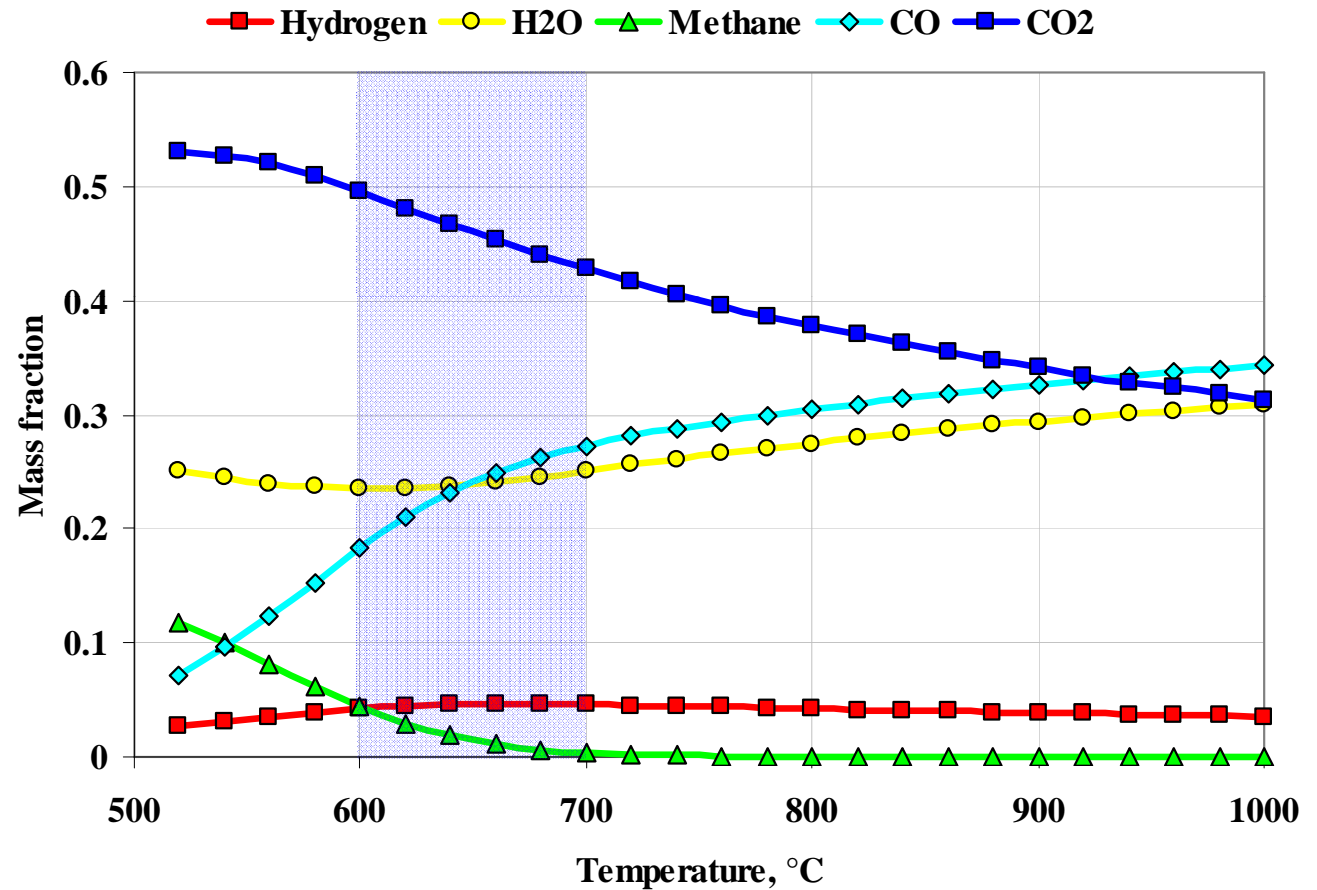



Introduction

Biofuels

MCFC

Results

Discussion

$$\begin{aligned}
 n_{H_2, \text{equivalent}} &= n_{H_2} + n_{CO} \\
 &+ 3 \cdot n_{CH_3OH} + 4 \cdot n_{CH_4} \\
 &+ 6 \cdot n_{C_2H_5OH} + 7 \cdot n_{C_2H_6} \\
 &+ 10 \cdot n_{C_3H_8} + 13 \cdot n_{C_4H_{10}}
 \end{aligned}$$

$$\eta_f = 1 - \frac{n_{H_2, \text{equivalent}, \text{out}}}{n_{H_2, \text{equivalent}, \text{in}}}$$



Introduction

Biofuels

MCFC

Results

Discussion

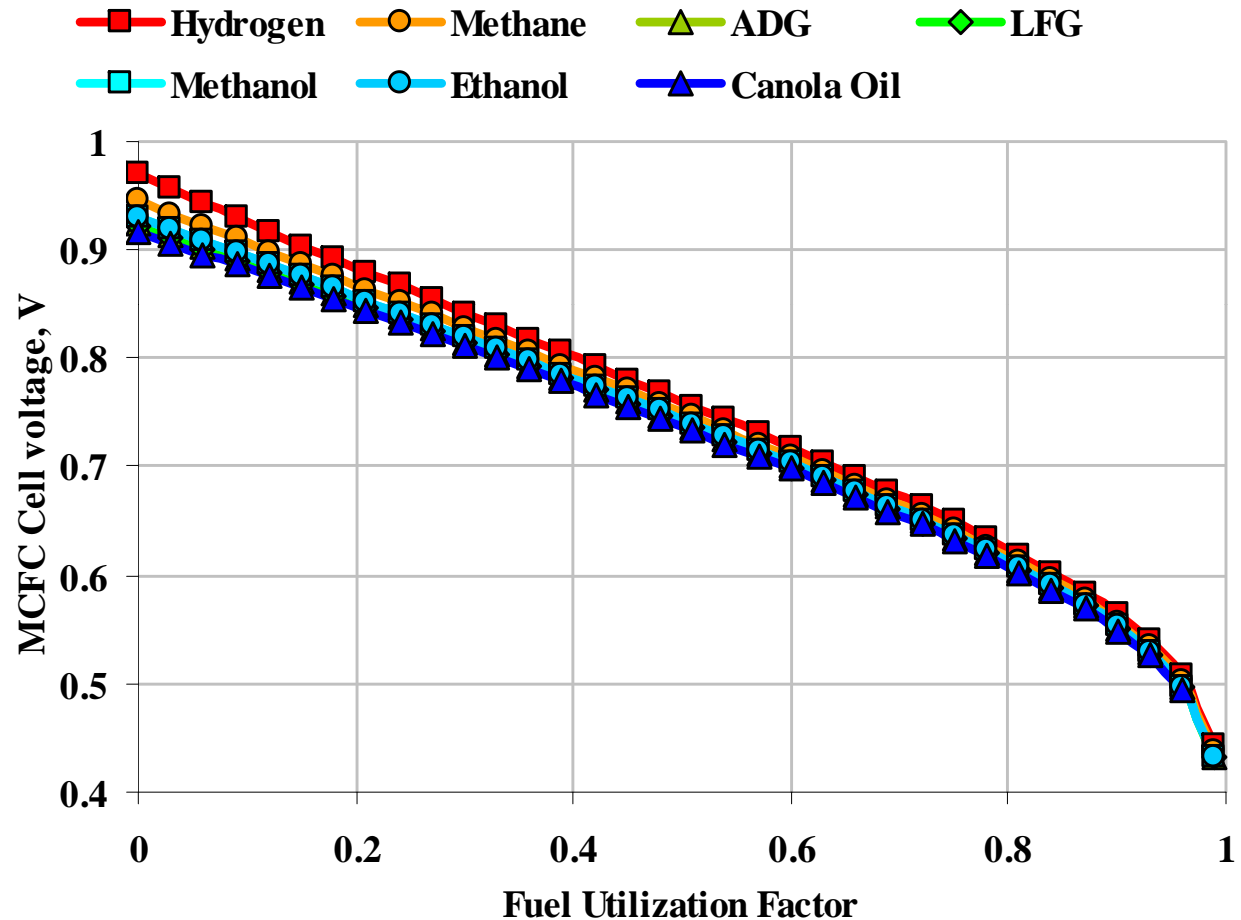



Introduction

Biofuels

MCFC

Results

Discussion

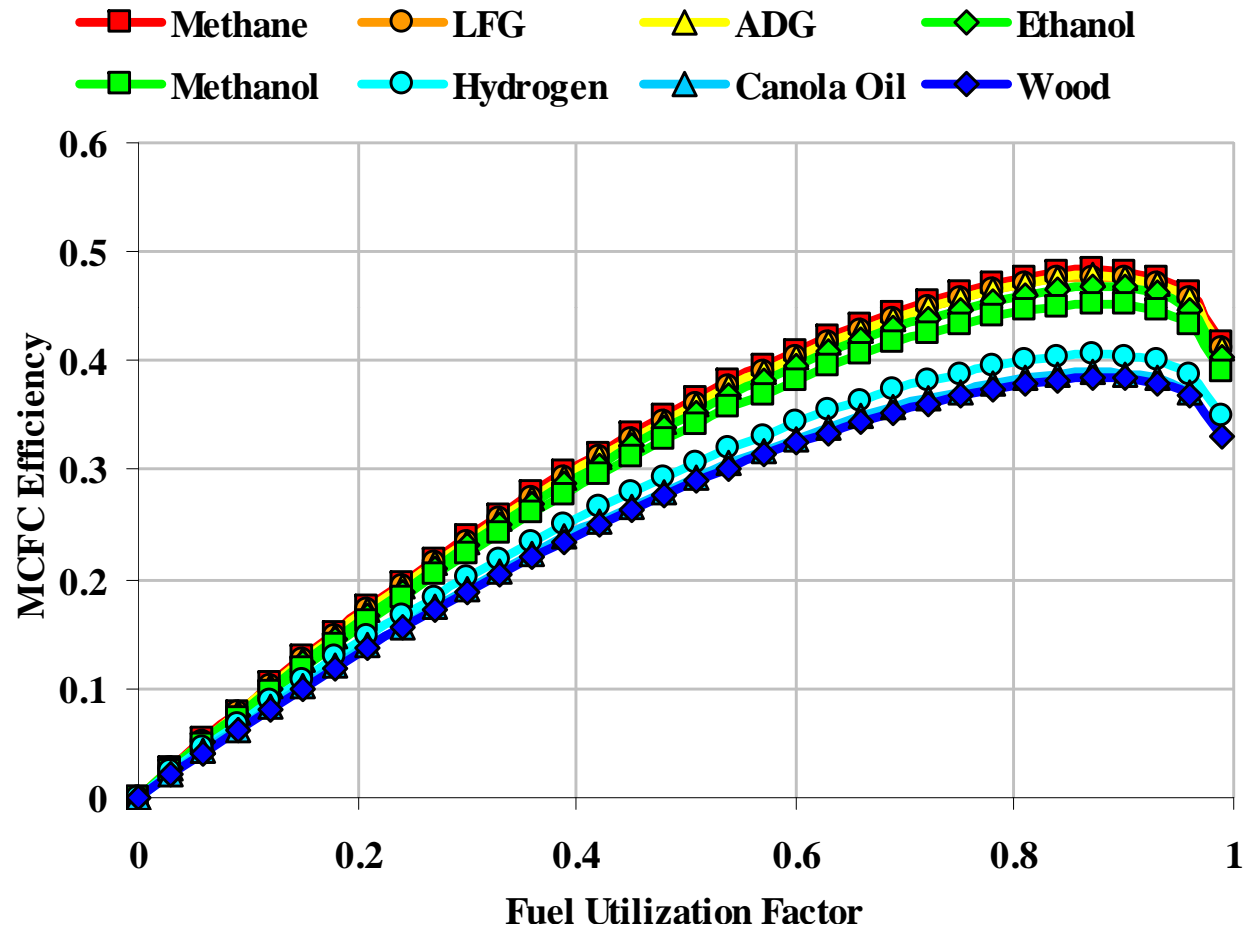



Introduction

Biofuels

MCFC

Results

Discussion

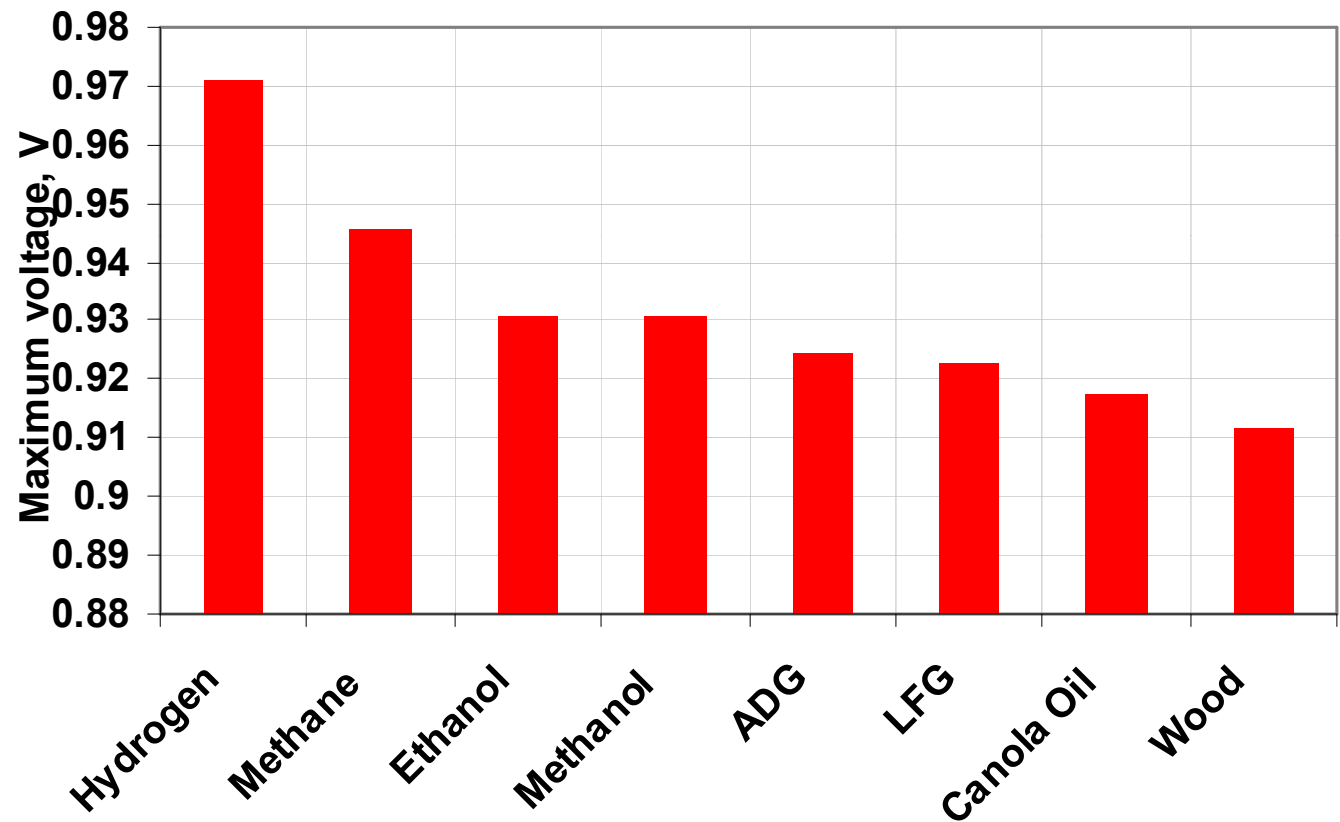



Introduction

Biofuels

MCFC

Results

Discussion

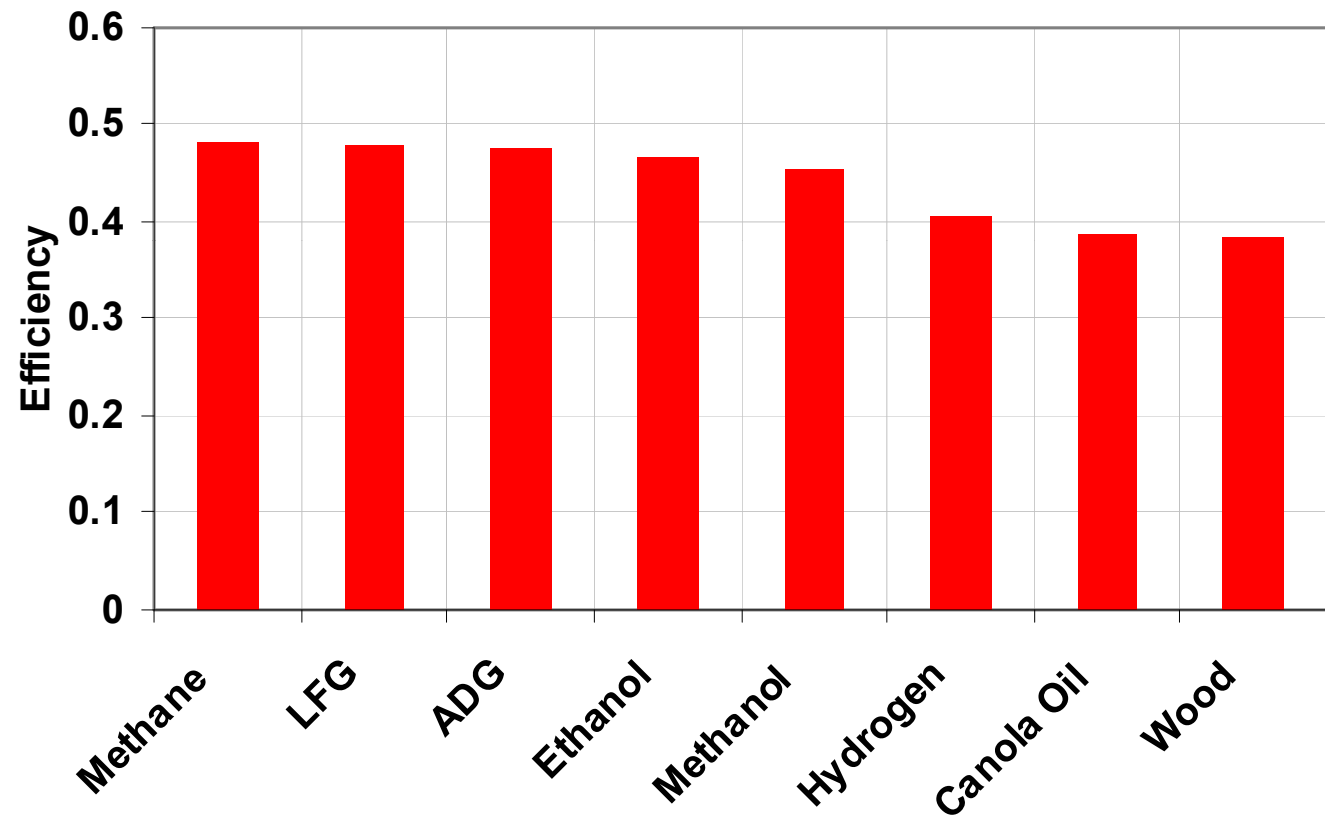



Introduction

Biofuels

MCFC

Results

**Discussion**

Biofuels utilization in MCFC means:

- lower efficiency
- lower fuel utilization factor
- pre-mixing with steam
- biogases outperforms other types of biofuels



# Molten Carbonate Fuel Cell Fuelled by Biofuels



**Introduction**

**Biofuels**

**MCFC**

**Results**

**Discussion**

**Thank you.**