



LARGE-SOFC - Towards a Large SOFC Power Plant

LARGE-SOFC, Towards a Large SOFC Power Plant

R. Rosenberg, J. Kiviaho, J. Göös, P. Jansson, O. C. Tarnowski, J. Jacobsen, L. Blum, R. Steinberger-Wilckens

Fuel Cell Seminar 2009



Fuel Cell Seminar 2009



Background

- ∅ European Fuel Cells and Hydrogen Joint Undertaking has established a target of 8-16 GW installed fuel cell power in 2020
- ∅ This is to be covered by a number of residential 1-2 kW units, 10-1000 kW industrial units and \geq MW stationary power plants
- ∅ The residential systems will be either PEFC or SOFC. Several European producers exist
- ∅ The industrial units and stationary power plants will be either MCFC or SOFC. Ansaldo and MTU are producers of MCFC systems
- ∅ Two European companies develop large SOFC systems. RRFCS develop stacks and whole systems while Wärtsilä is system integrator with TOFC as SOFC stack producer



Large-SOFC, an EU Integrated Project

- ∅ The European Commission is co-funding the project in order to support the industry in its efforts to develop commercial SOFC stationary power plants
- ∅ Duration of project is three years 2007-2009
- ∅ Budget 11 M€ of which commission grant 5.8 M€

- ∅ **The aim of the project is to address the basic problems when moving from kW to MW size SOFC power plants**
- ∅ **Development and verification of**
 - **Concepts**
 - **Components**
 - **Sub-systems**

- ∅ Long term goal of the development
 - **Commercial life time and cost**
 - **Electrical efficiency up to 60%, CHP efficiency >80%**



Participants

| | | |
|--|----------|----|
| VTT Technical Research Centre of Finland | VTT | FI |
| Wärtsilä Finland | Wärtsilä | FI |
| Rolls-Royce Fuel Cell Systems Ltd | RRFCS | UK |
| Topsoe Fuel Cell A/S | TOFC | DK |
| Forschungszentrum Jülich GmbH | FZJ | DE |
| Dipartimento di Ingegneria Chimica e di Processo "G.B. Bonino" - Università di Genova | UNIGE | IT |
| BOSAL RESEARCH nv | Bosal | B |
| The Switch Oy | Switch | FI |
| Inmatec Technologies GmbH | Inmatec | DE |

Target design to be developed: parallel development

- ∅ SOFC technology has two main streams, atmospheric and pressurised - each have specific features and advantages.
- ∅ Both technologies have applications to future power generation needs
 - ∅ Hybrids for ultimate electrical efficiency & multi MW range.
 - ∅ Atmospheric 0,5 – 5 MW CHP applications in distributed generation.

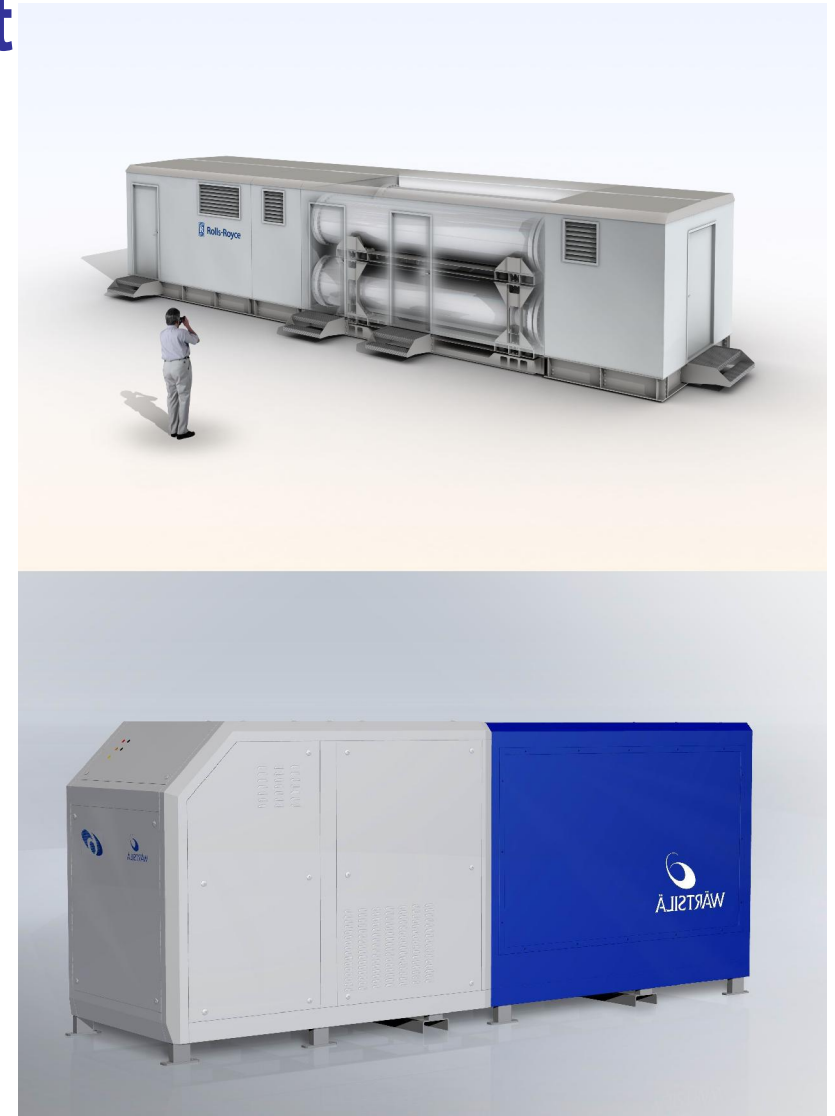



Components and subsystems

The objective is to develop new and test commercially available components and sub-systems which need to be

- Ø Efficient
- Ø Effective
- Ø Affordable

The components are

- Ø Combustor equipment for start-up and stack off-gas burning.
- Ø Fuel and air re-circulation equipment.
- Ø Heat exchanges and recuperators
- Ø Fuel processing equipment for normal operation, start up and fuel flexibility.
- Ø Power electronics and control systems



Pressurized system of RRFCS

Ø1 MW comprising
four 250 kW stack
units.

Ø Target is cost
optimisation with
minimum
components

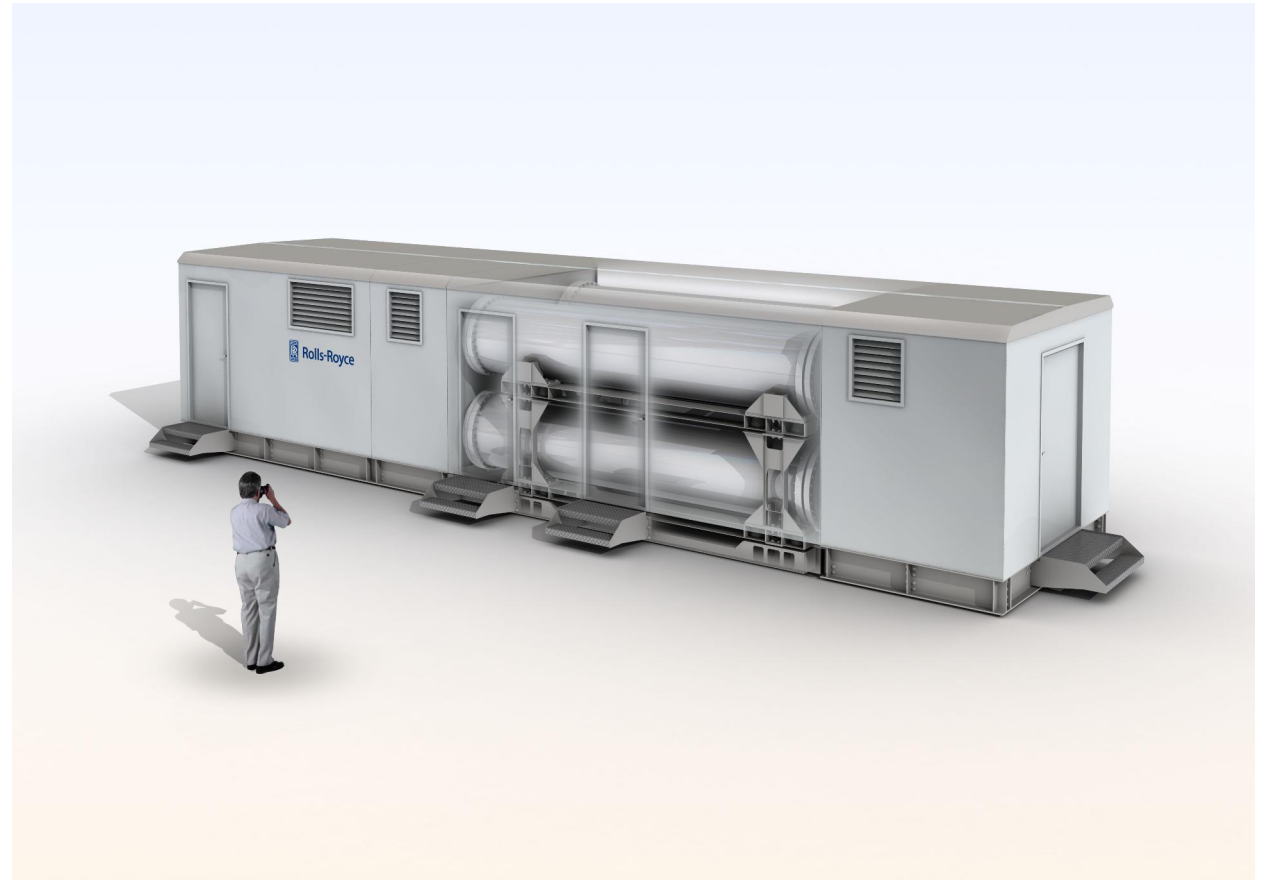

New pressurized system concept

Ø New concepts replace cathode ejector with blowers and original bespoke microturbine with Turbec 100:

Ø 55% electrical efficiency increases to almost 60%.

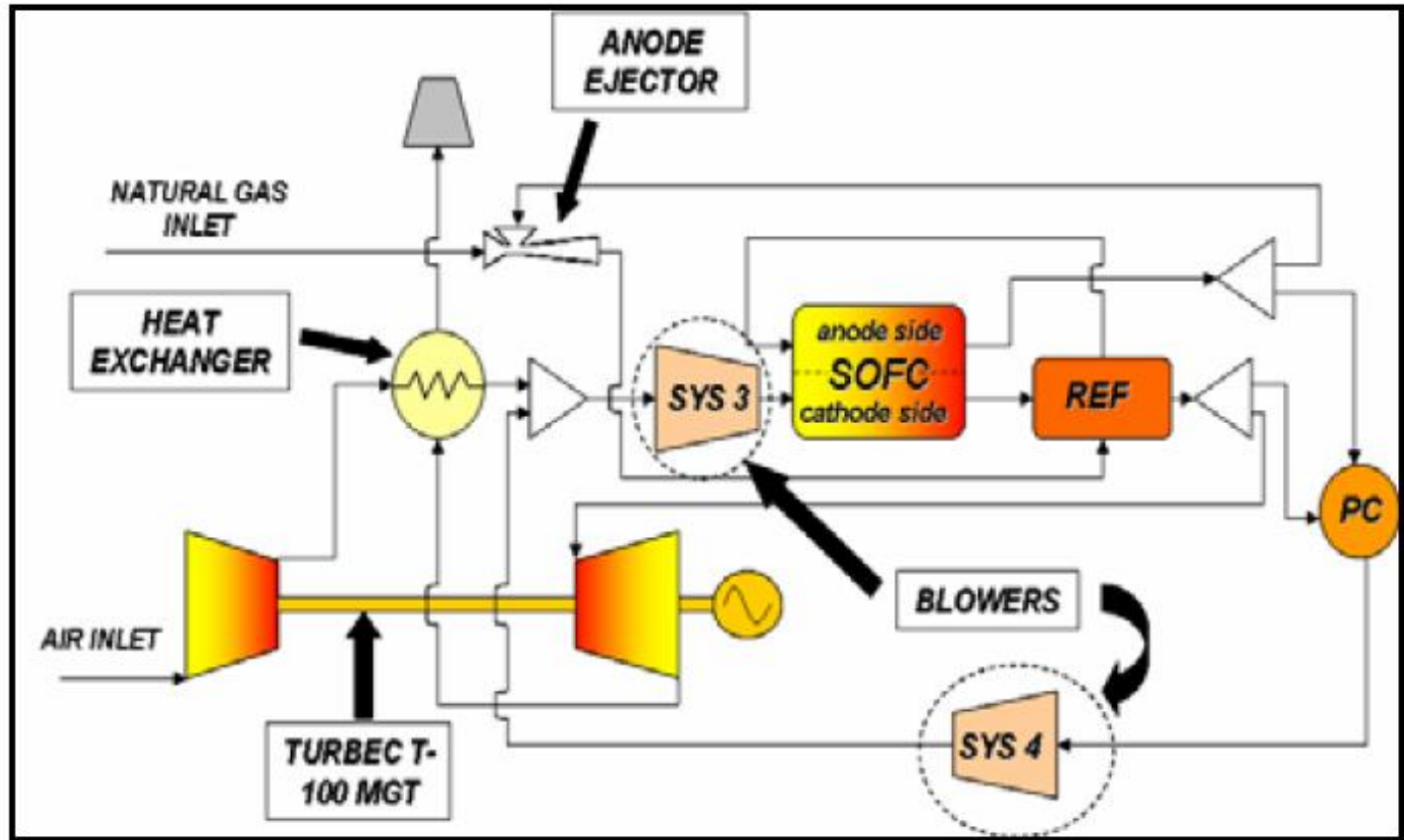



Large SOFC including gasification of coal and carbon capture and storage (CCS)

- Ø 20 units of 5 MW
- Ø Electrical efficiency 41% with CCS and 47% without CCS
- Ø In comparison Integrated Gasification Combined Cycle (IGCC) plant: 31% with CO₂ capture

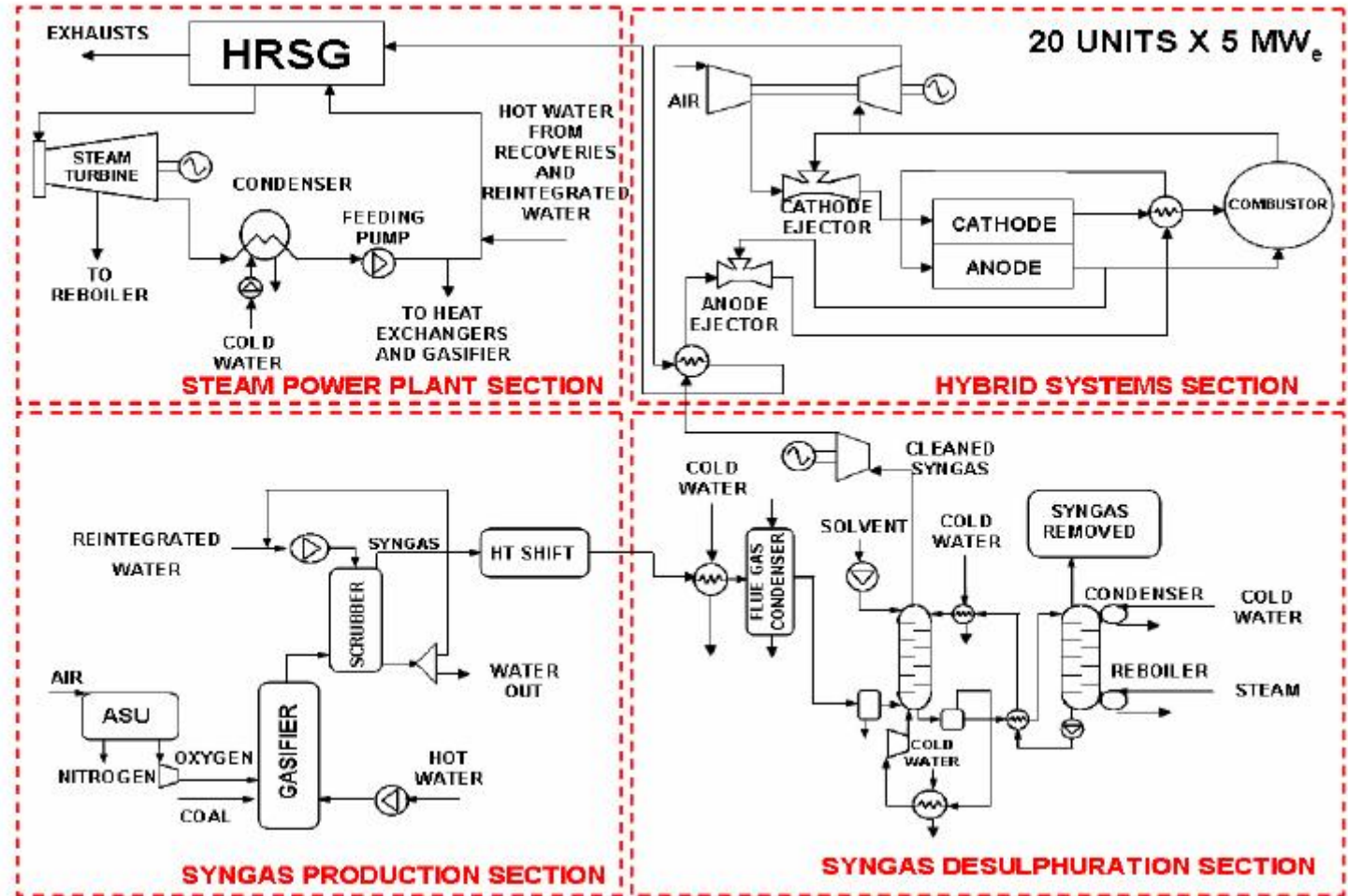

Turbo machinery, gas and air circulation

University of Genoa test facilities are used to

- Ø Analysis of anode and cathode recirculation devices
- Ø Flu dynamic interaction between micro turbine and stack
- Ø Micro turbine control strategies
- Ø Validation of models

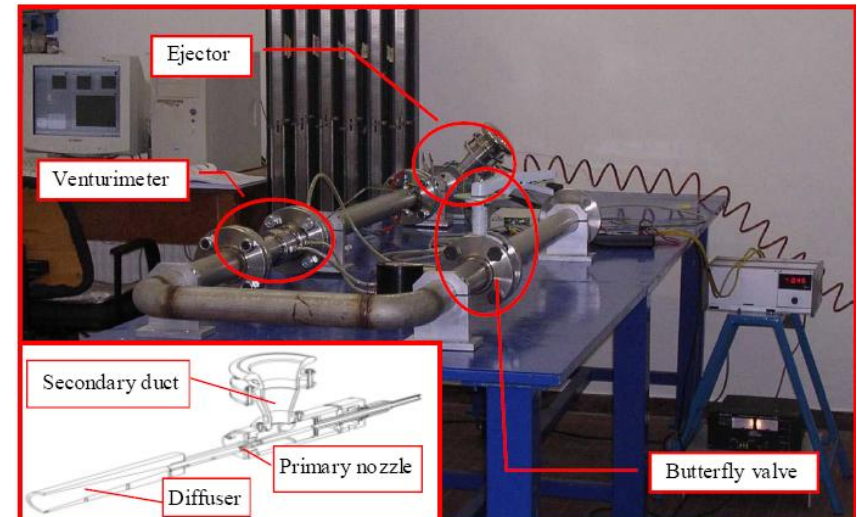
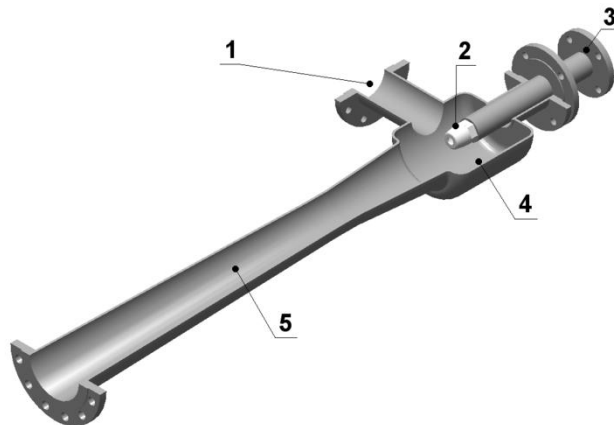

Heat exchangers and recuperators.

- Ø The goal is the analysis of heat exchanger materials in order to optimise heat exchanger corrosion properties and cost
- Ø Bosal developed test stands for testing metal materials for heat exchangers
- Ø Mechanical properties including creep tests and chemical stability for a number of materials have been performed



Ceramic materials for pressurized stack

- ∅ New cost and performance optimised ceramic support materials are developed taking into account
- ∅ Thermal expansion
- ∅ Gas permeability
- ∅ Chemical compatibility
- ∅ Stability at temperatures
- ∅ Low cost

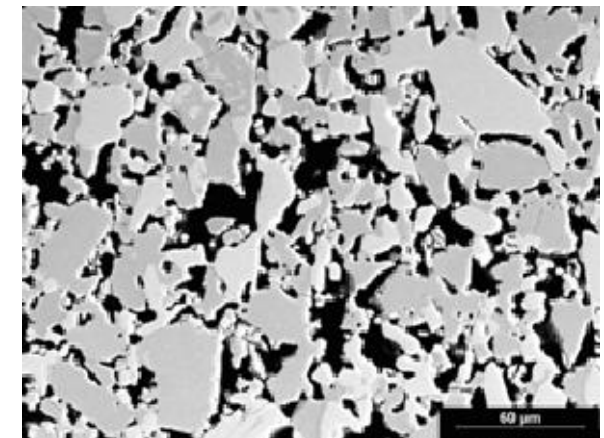
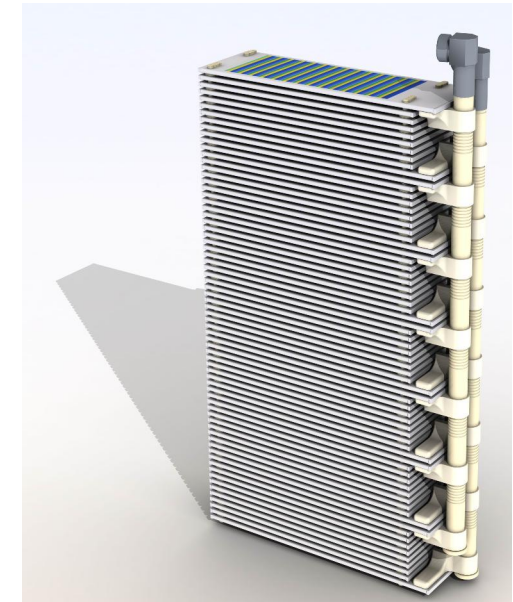

Non pressurized 50 kW system

To take into account:

Ø Efficiency

Ø Reliability

Ø Maintainability

Ø Cost

Ø Availability

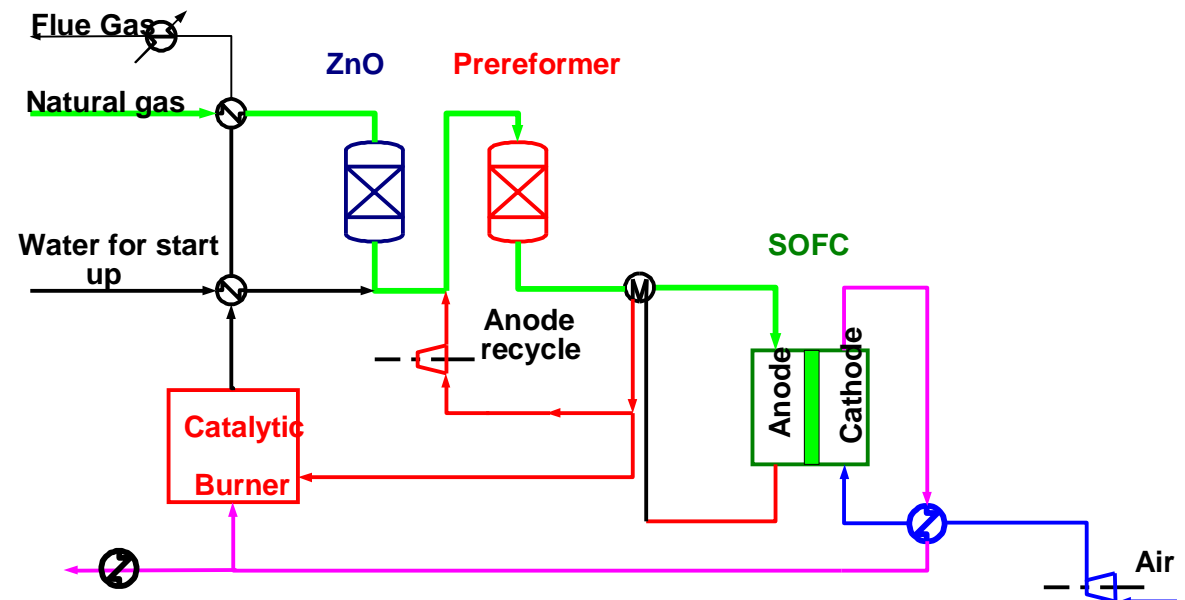

System analysis of 50 kW unit

- ∅ Three concepts with different anode recycle have been analysed.
- ∅ Catalytic burner and thermal burner.
- ∅ Different air heating and pre-reformer heating regimes.
- ∅ Very small differences in electrical efficiency found
- ∅ Next step different cell voltages and compressor efficiencies used.
- ∅ System net efficiencies between 46% and 56% were found. It was also noted that auto thermal reforming results in low efficiency: 29%.

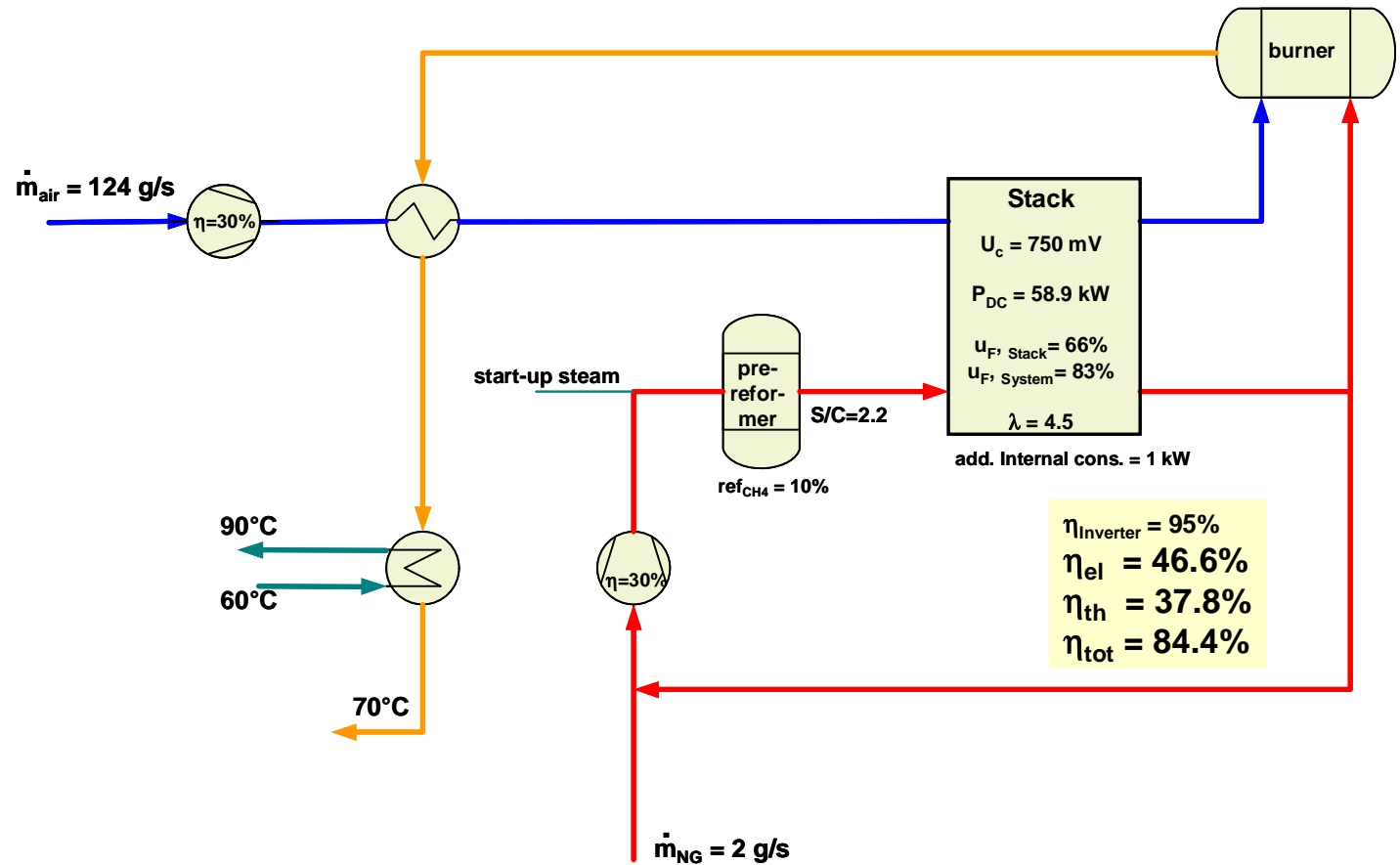

Stack development and integration

- Ø 18*18 cm cells
- Ø 60 cell stack
- Ø Co- or counter flow
- Ø Nominal output 2.5 kW
- Ø 24 stacks gives 50 kW net for system
- Ø A four stack module has been developed

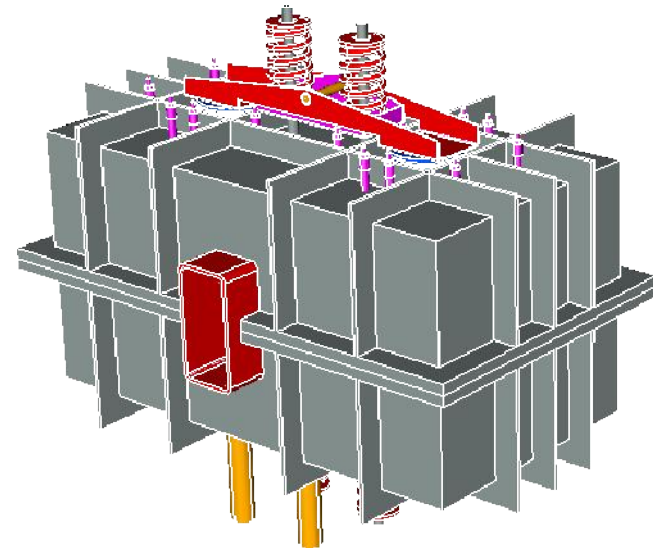
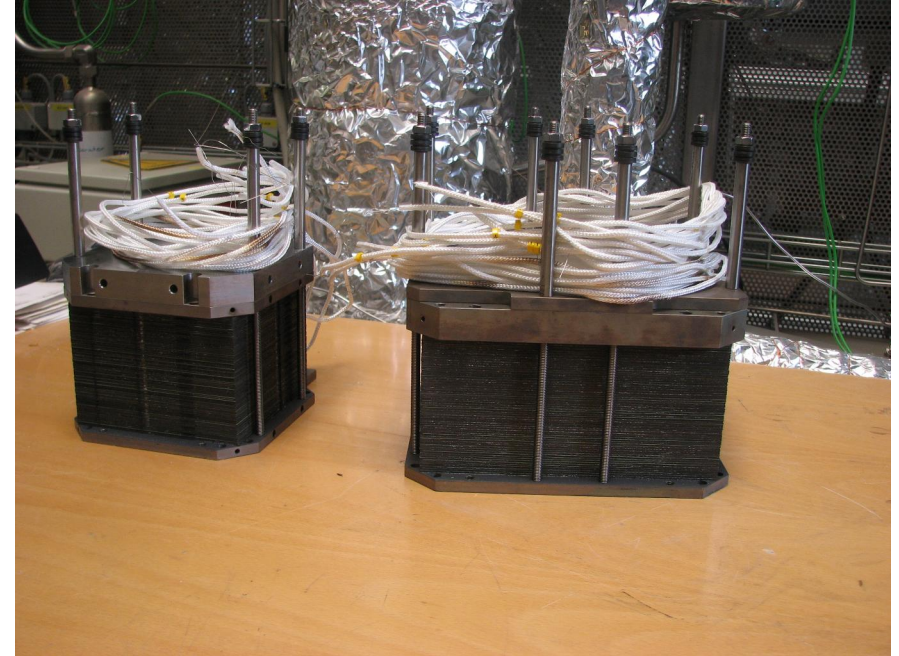

System design

Improved concepts:

Ø Heat zone optimisation

Ø System, sub-system and component integration

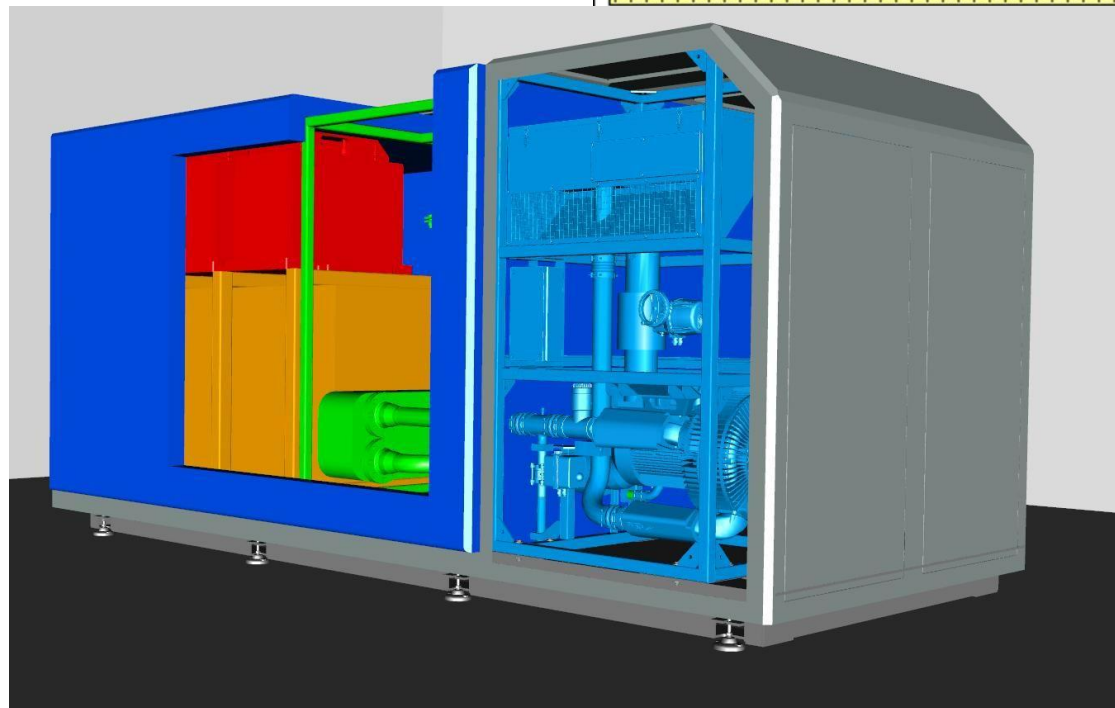
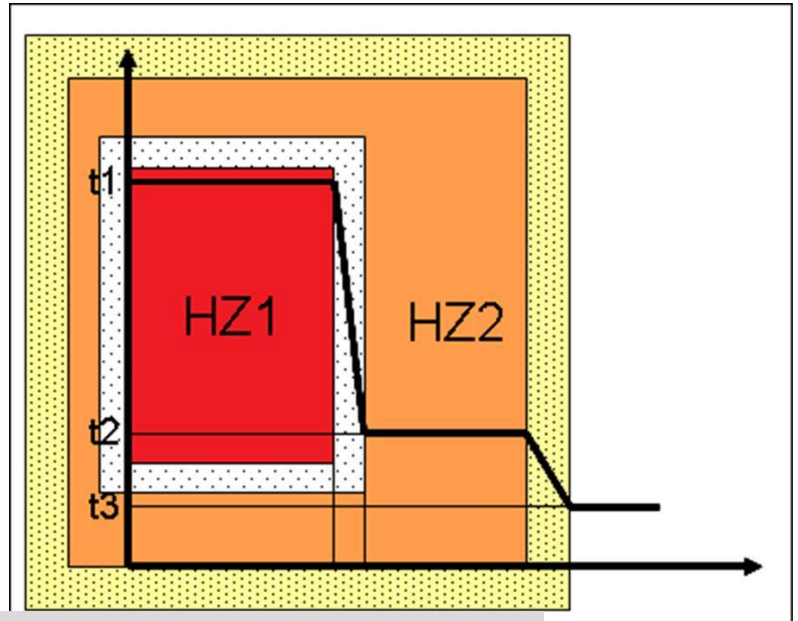

Insulation

- Ø Insulation materials properties have been studied
- Ø Low thermal conductivity resulting in thinner insulations
- Ø Less volume

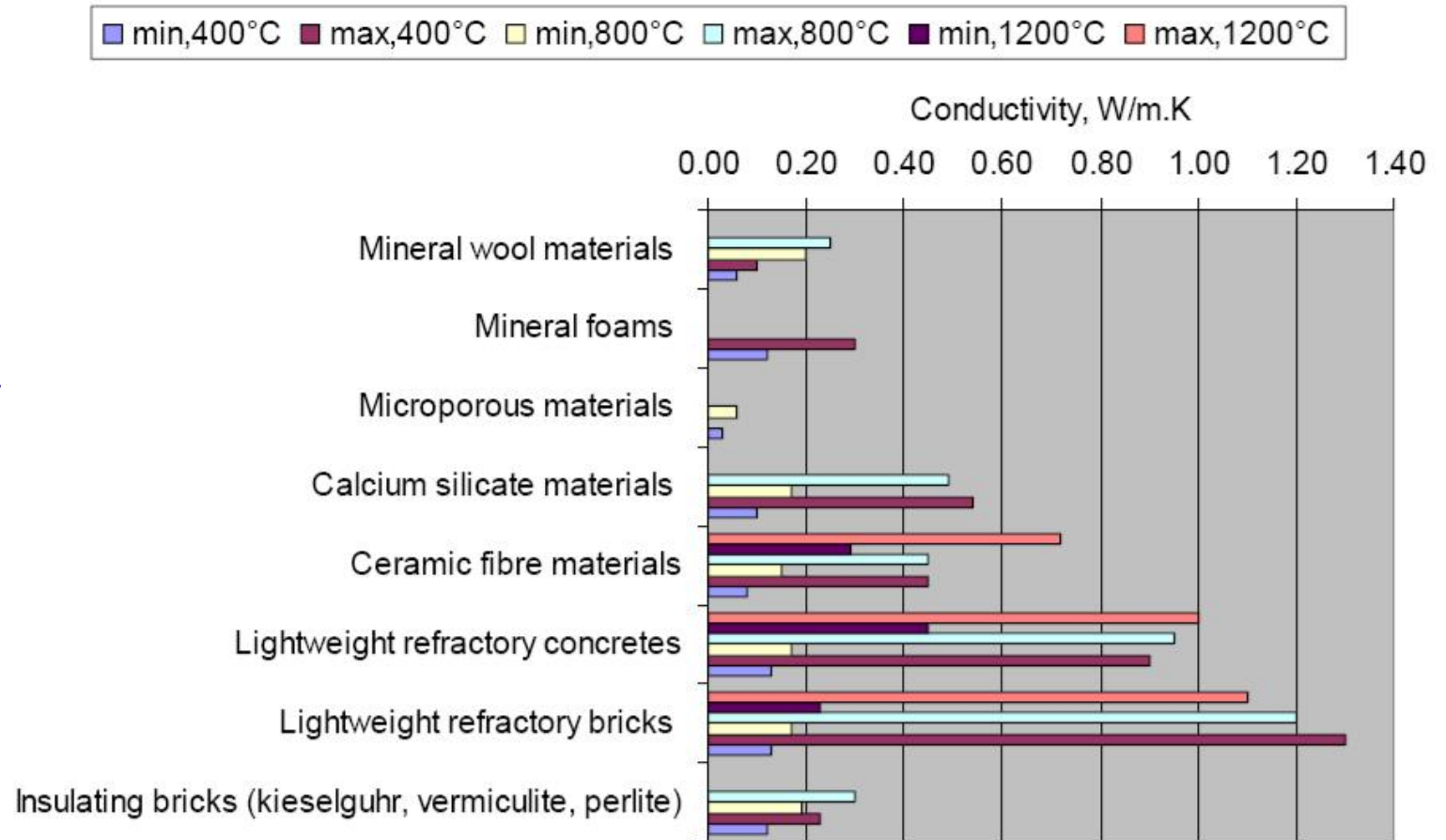

Air blowers and anode recirculation blowers for non-pressurised systems

A centrifugal compressor was developed and tested

Ø Automotive supercharger with new design electric motor was developed and tested.

- Ø Anode recirculation blower must stand heat (300 °C)
- Ø One existing unit has been tested

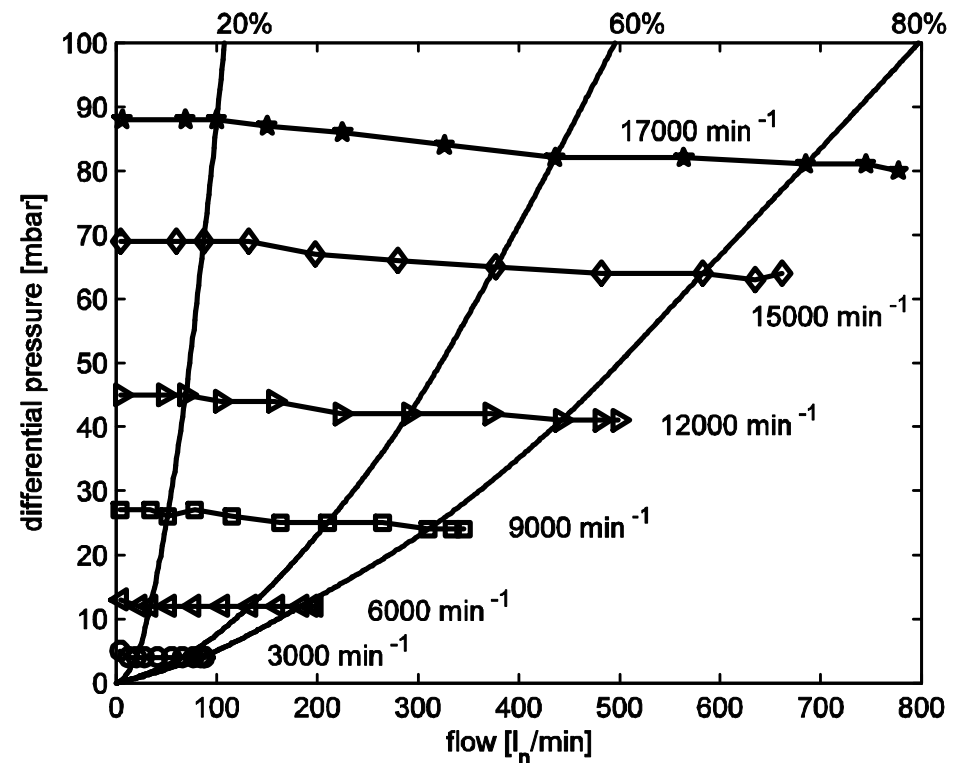

Heat exchangers.

- Ø Wärtsilä has studied manufacturing, performance and cost of different heat exchangers
- Ø Test device have been constructed
- Ø Heat exchangers will be purchased and tested
- Ø FZJ has constructed new test bench for heat exchanger testing

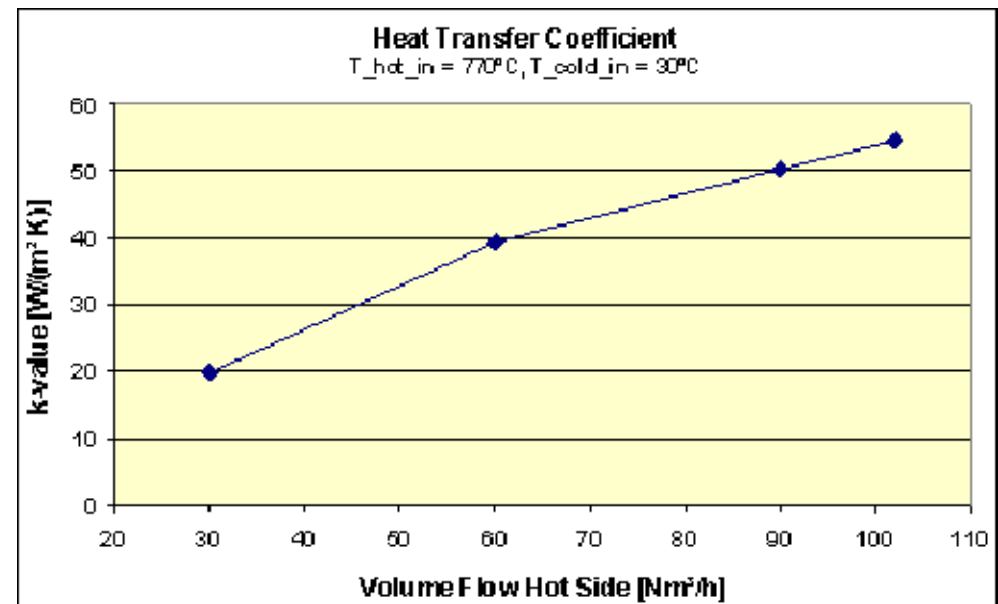
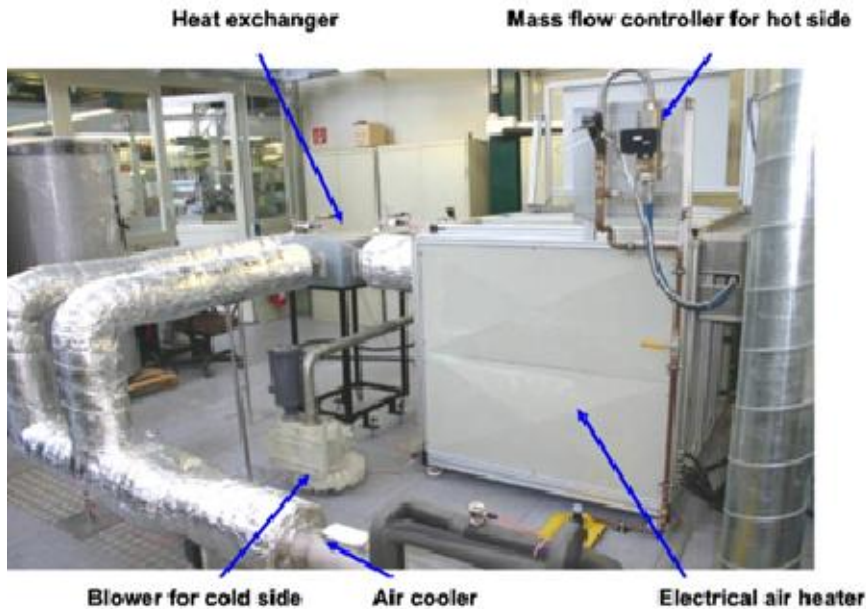

Fuel processing equipment

- Ø Analysis of fuel processing options in regard to performance and cost
- Ø An integrated steam reformer including heat exchangers, electrical heater and reformer was designed

Ø Thermodynamical calculations on recycle fractions performed

On Feed dry

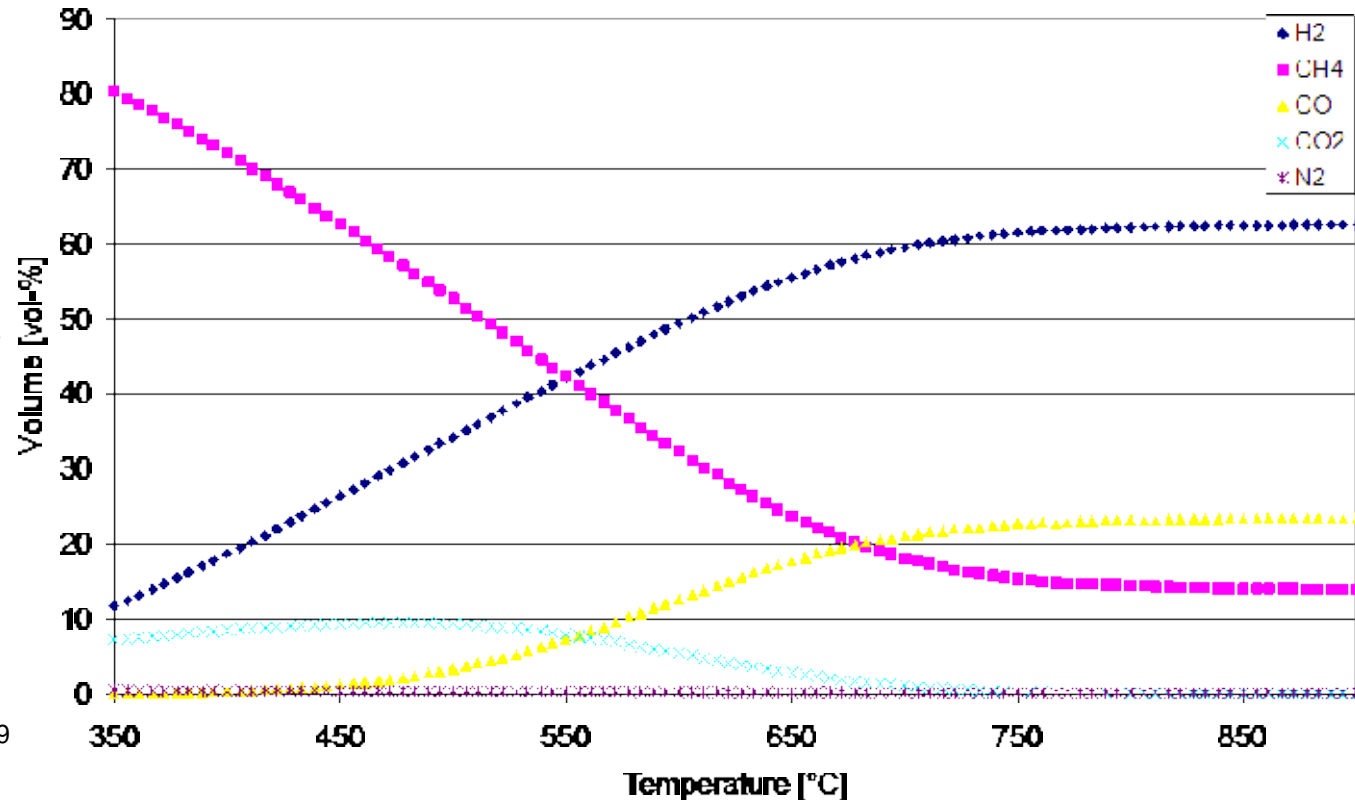

Power electronics

Analysis of requirements

∅ Controllability and sensitivity to stack variation

∅ Isolation requirements

∅ Cabling arrangement and losses

∅ Power conversion arrangement and complexity

∅ Stack monitoring and protection arrangements

∅ A test rig was constructed (Wärtsilä)

∅ A prototype concept for power electronics has been designed

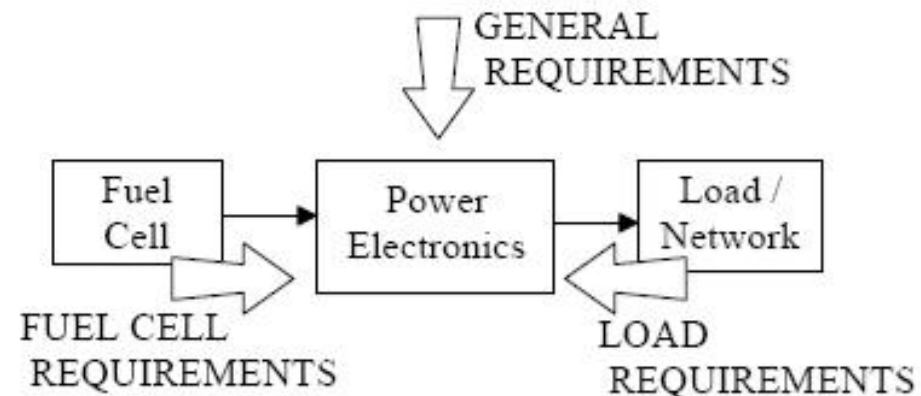

Concept verification

The objective is to verify the concepts for system and sub-systems developed in this project and related projects. The concepts are

Ø50 kW SOFC atmospheric CHP plant

ØComponents for 50 kW SOFC have been verified; blowers, heat exchangers and reformers



Supporting activities

The objectives are to ensure that the most relevant issues of using a SOFC power plant are clarified

Ø Fuel quality requirements, gas cleaning, fuel processing options

- Focus on biofuels
- Influence of toluene, HCN and HCl on cells

Ø Grid connection rules and standards in Finland, UK, other EU

- Focus on islanding issues and requirements of isolating transformer

Ø Safety and standards

- Safety requirements, legal regulations and standardisation

Biofuels in the EU-15

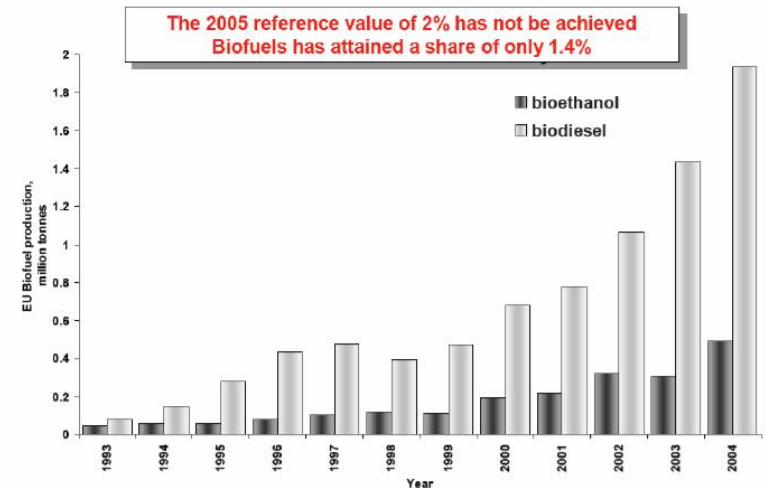

Life cycle analysis

- ∅ Comparison of 50 kW non-pressurised with pressurised and other power plants
- ∅ Including different fuels
- ∅ Starting from raw materials to operation and recycling when dismantled

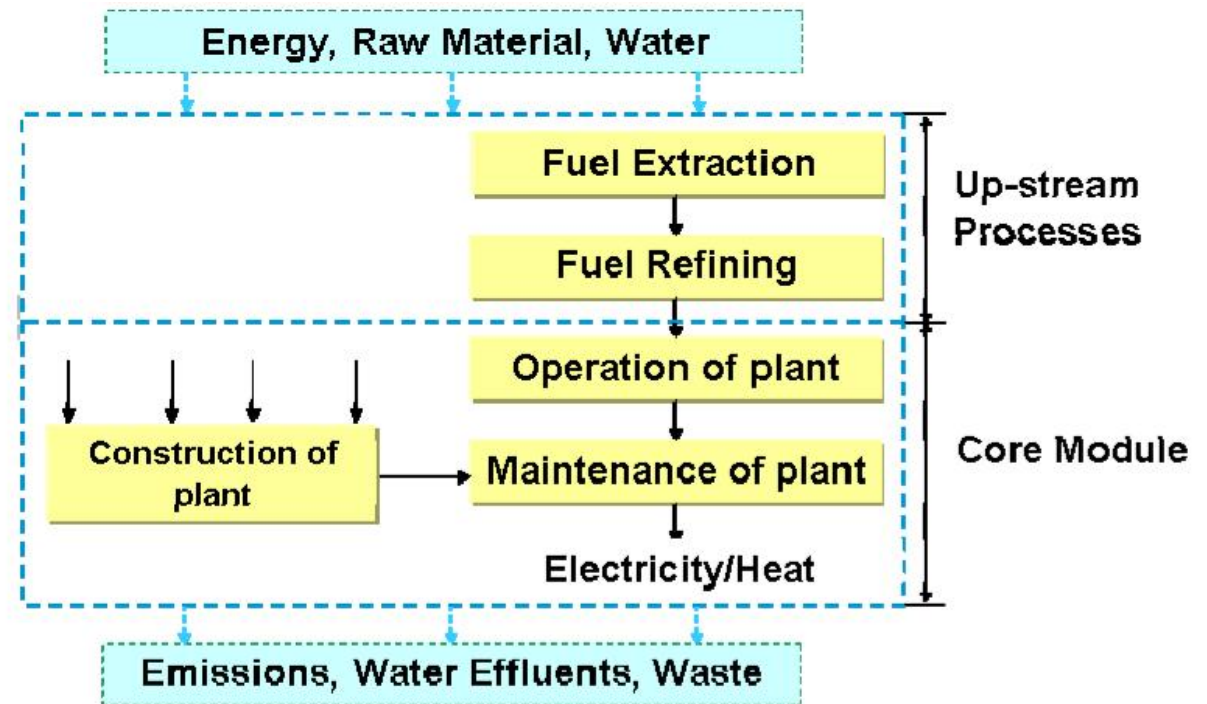

The preliminary results shows an clear advantage for SOFC compared with Conventional natural gas power plant



Training and dissemination

- Ø Technology workshops
 - Ø Internal workshops
 - Ø Two public workshops on BoP and system issues

- Ø Summer schools
 - Ø Two summer schools as a continuation of those organised by Real-SOFC



*Introduction to Solid Oxide Fuel Cell Science and Technology
Chania, Crete 2008*





Acknowledgements

The EU FP6 and the National Funding Agency for Technology and innovation (Tekes) are acknowledged for their support by funding the project.

The project partners, Erkkko Fontell and Kim Eklund (Wärtsilä), Yves de Vos, Jean-Paul Janssens (Bosal), Jonathan Lewis and Olivier Tarnowski (RRFCS), Ludger Blum and Robert Steinberger- Wilckens (FZJ), Loredana Magistri, Renzo Di Felice, Aristide F. Massardo (UNIGE), Reijo Takala (The Switch), and Moritz v. Witzleben (Inmatec) as well as the whole project group are also acknowledged for their contributions to the work.



Thank you for your attention