



FuelCell Energy

Ultra-Clean, Efficient, Reliable Power

Oral: Abstract: 439

Co-production of Renewable Hydrogen and Electricity: Technology Development and Demonstration

**P. Patel, L. Lipp, F. Jahnke,
FuelCell Energy, Inc. Danbury, CT**

**F. Holcomb, T. Abdallah
U.S. Army Corps of Engineers
Engineer Research and Development Center (ERDC-CERL)**

**E. Heydorn
Air Products and Chemicals, Inc.**

**2009 Fuel Cell Seminar & Exposition
Palm Springs, CA**

November 16-19, 2009

reliable, efficient, ultra-clean



Financial Support

- U.S. DoD – Army Corps of Engineers – ERDC-CERL
- Air Products and Chemicals, Inc. (DOE-EERE)
- Connecticut Clean Energy Fund (CCEF)
- FuelCell Energy, Inc.

Disclaimer

This presentation contains forward-looking statements, including statements regarding the company's plans and expectations regarding the development and commercialization of fuel cell technology. All forward-looking statements are subject to risks and uncertainties that could cause actual results to differ materially from those projected. The forward-looking statements speak only as of the date of this presentation. The company expressly disclaims any obligation or undertaking to release publicly any updates or revisions to any such statements to reflect any change in the company's expectations or any change in events, conditions or circumstances on which any such statements are based.



- **Hydrogen Co-Production Concept (DFC-H₂[®])**
- **Hydrogen Co-Production Demonstration Status**
- **Advanced H₂ Separation Technology Development**
- **Renewable Fuel Capability**
- **Near-term Deployment Strategy (Applications/Challenges)**
- **Summary**



FuelCell Energy
Ultra-Clean, Efficient, Reliable Power

Leveraging Civil/Military Power Requirements

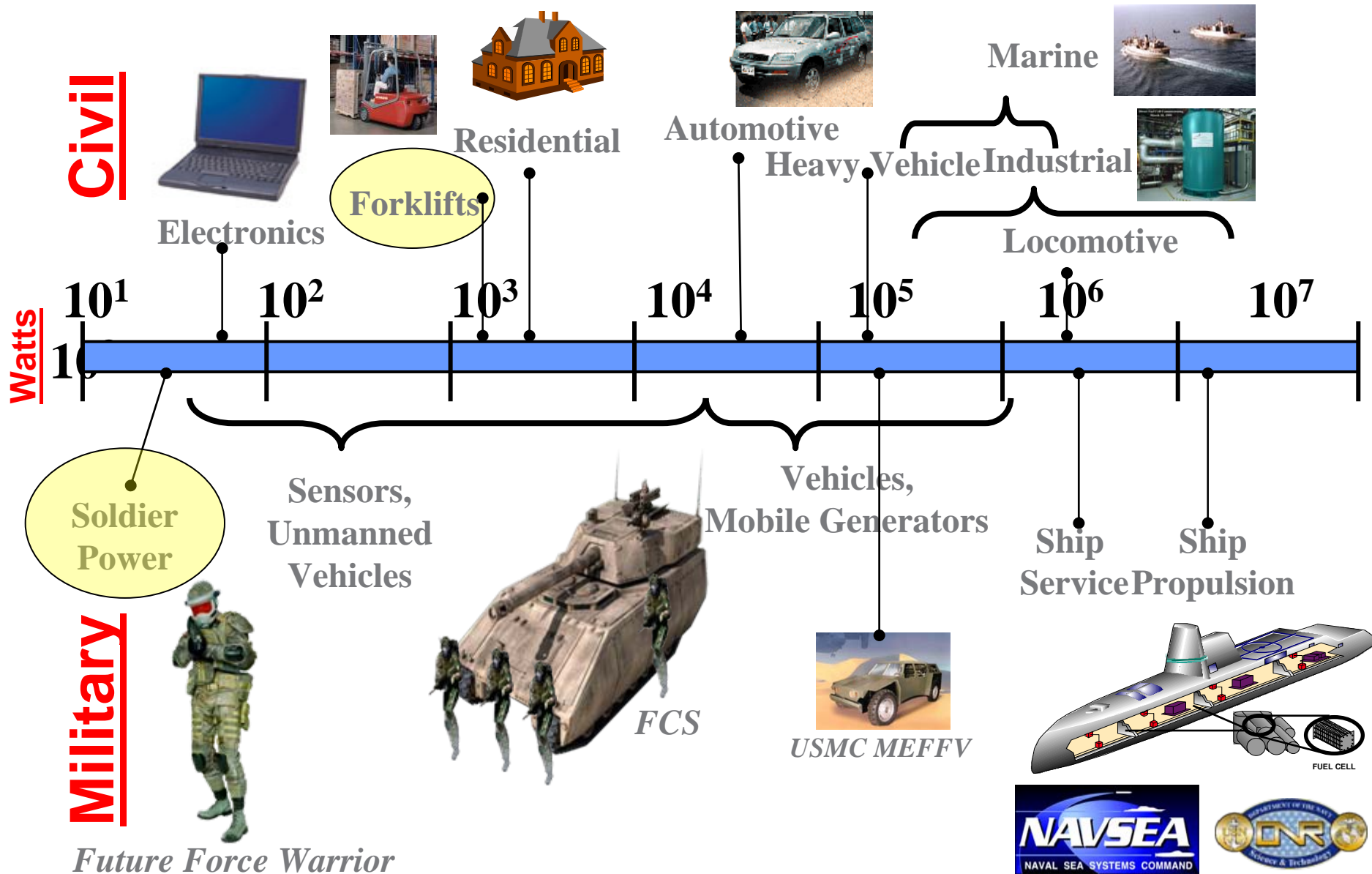



FuelCell Energy
Ultra-Clean, Efficient, Reliable Power

Hydrogen Logistics Initiative

Fuel Cell Benefit to DoD

Direct benefit to military applications

- Increased Fuel Efficiency
- Quiet, low-heat, zero-emissions
- Energy density
- Fuel diversity



Soldier Power



COMBATT APU



UAV



UUV

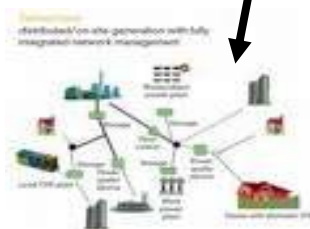
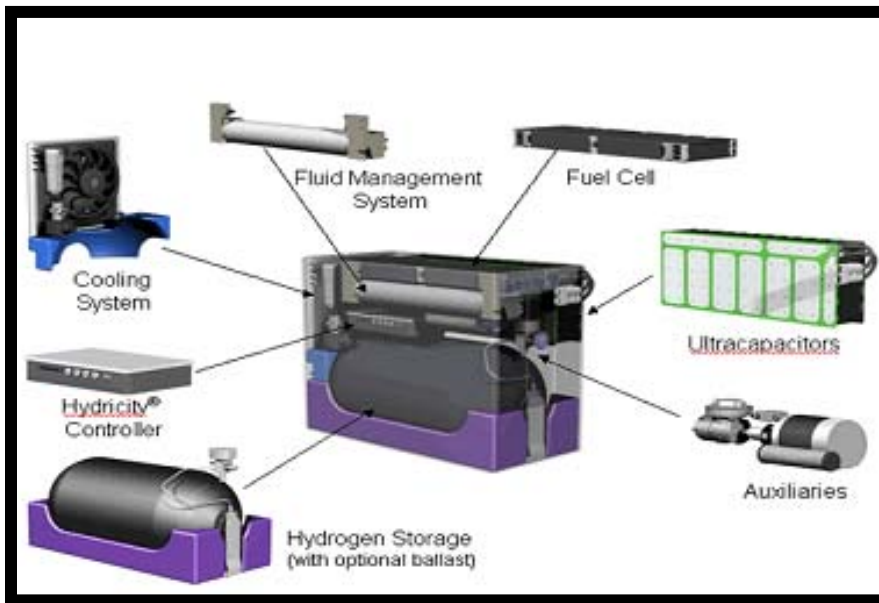

Micro-grids



Portable Gen-sets



DDX



FuelCell Energy
Ultra-Clean, Efficient, Reliable Power

FCE Overview

- **Leading fuel cell developer for 40 years**
 - MCFC, SOFC, PAFC and PEM (up to 2.8 MW size)
 - Over 340 million kWh of clean power produced worldwide (>50 installations)
 - Renewable fuels: over two dozen units with ADG fuel
 - Ultra-clean technology: CARB-2007 certified
- **Highly innovative approach to fuel cell development**
 - Internal reforming technology (45-50% electrical efficiency)
 - Fuel cell-turbine hybrid system (55-65% electrical eff.)
 - Enabling technologies for hydrogen infrastructure
 - Co-production of renewable H₂ and electricity
 - Solid state hydrogen separation and compression



Danbury, CT



Torrington, CT



FuelCell Energy
Ultra-Clean, Efficient, Reliable Power

Core Product: DFC[®] Cells and Stack Modules

FCE Manufactures complete Direct FuelCell[®] cells and stack modules from raw materials and purchased parts in our Torrington, CT manufacturing facility

Electrode, Matrix and Bipolar Plate Manufacturing



Assembled Cell Package with Internal Reformer





FuelCell Energy
Ultra-Clean, Efficient, Reliable Power

Building Block Approach to Product Line



Cell Package and Stack



Single-Stack Module



Four-Stack Module



DFC300
Single Module Power Plant

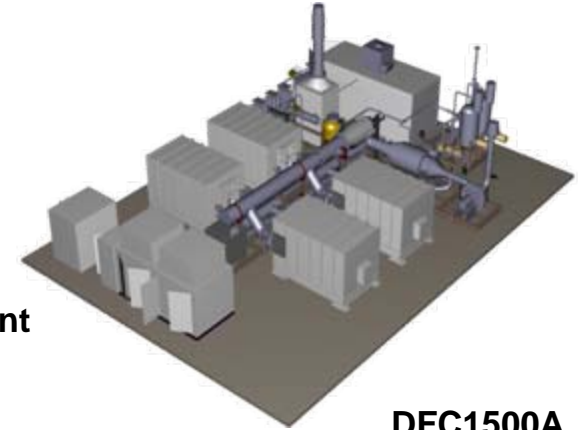

DFC1500A
Four Module Power Plant

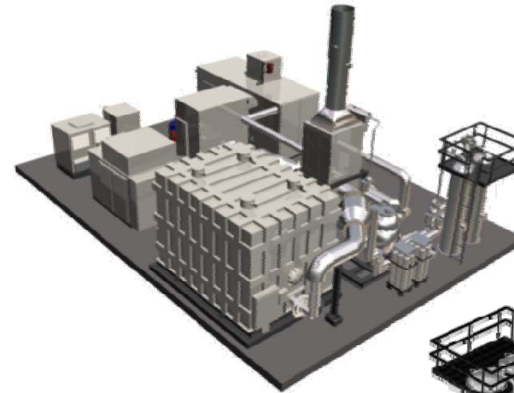

DFC1500B
One 4-Stack Module

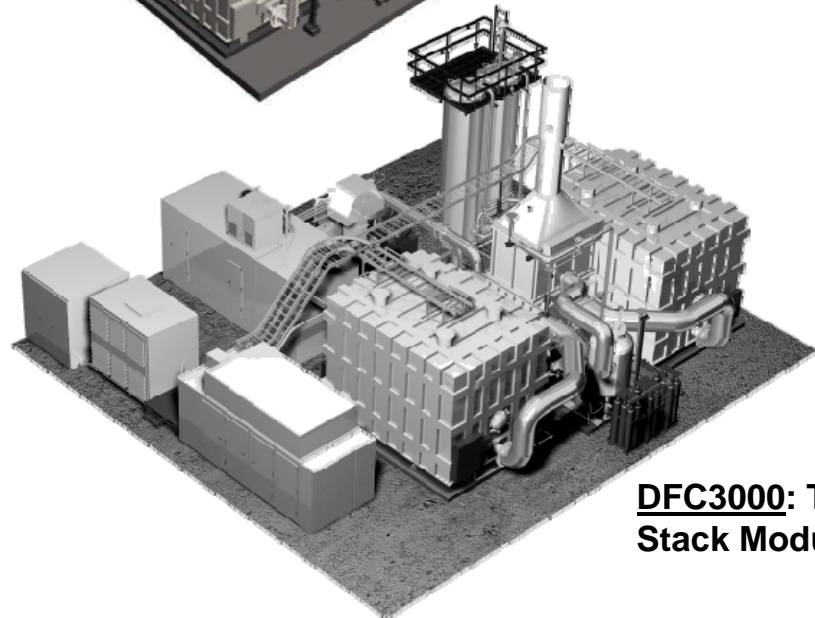

DFC3000: **Two 4 Stack Modules**



FuelCell Energy
Ultra-Clean, Efficient, Reliable Power

DFC[®] Power Plant Locations

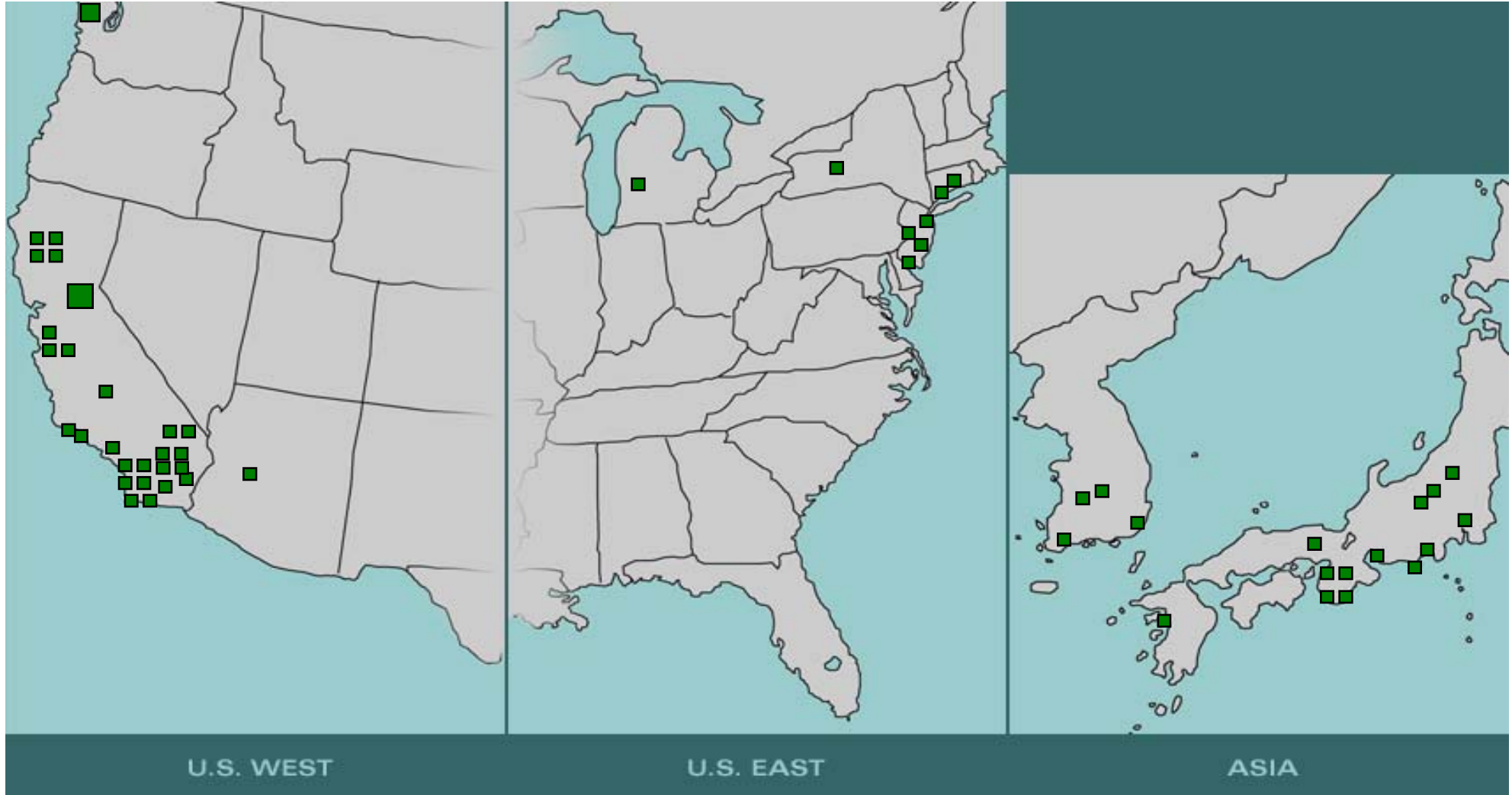

More than 10,000 kg H₂/day being produced in CA alone – mostly from renewable fuels (ADG)



FuelCell Energy
Ultra-Clean, Efficient, Reliable Power

Commercial DFC[®] Configuration

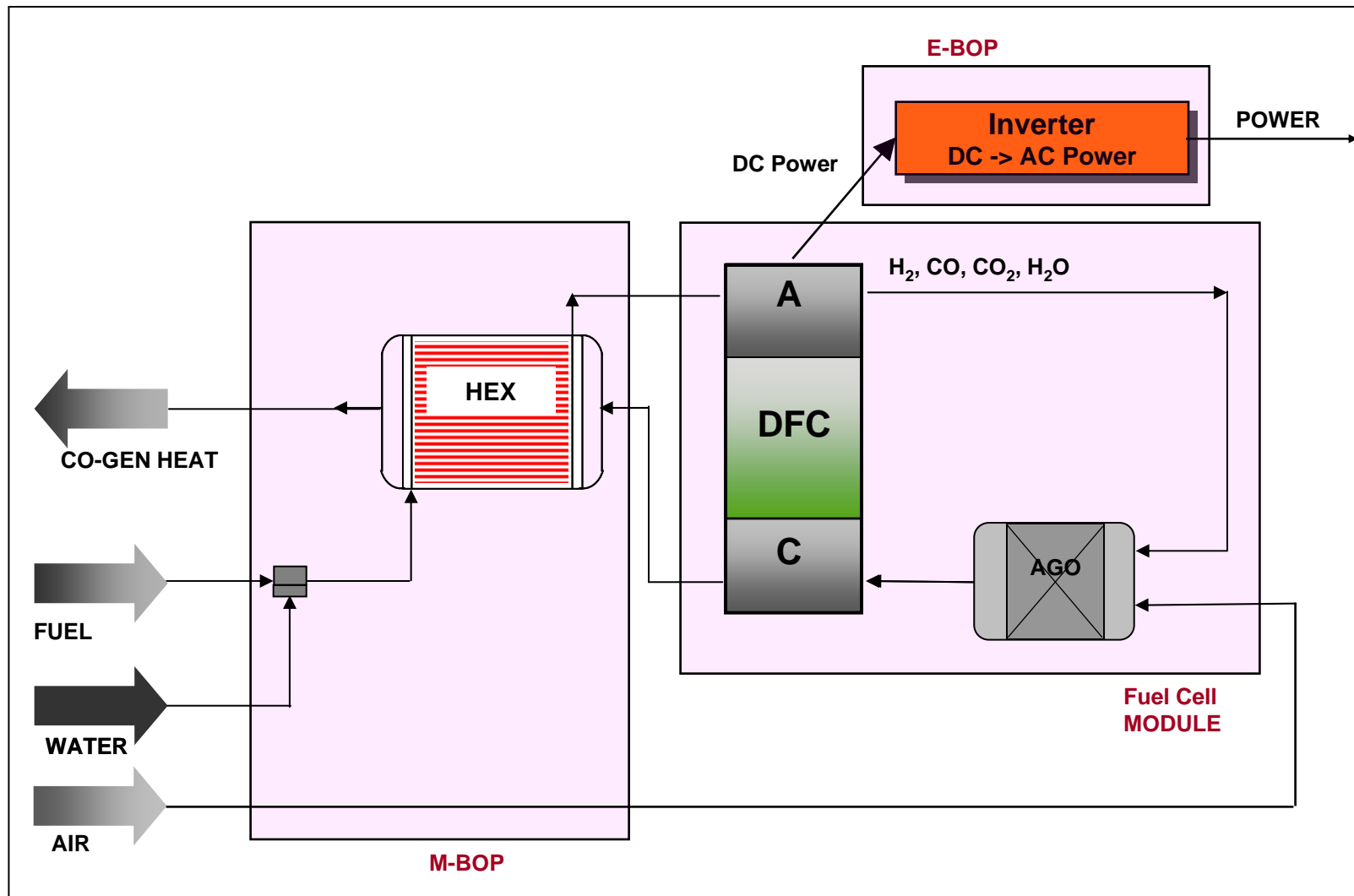



FuelCell Energy
Ultra-Clean, Efficient, Reliable Power

DFC-H2[®] Configuration

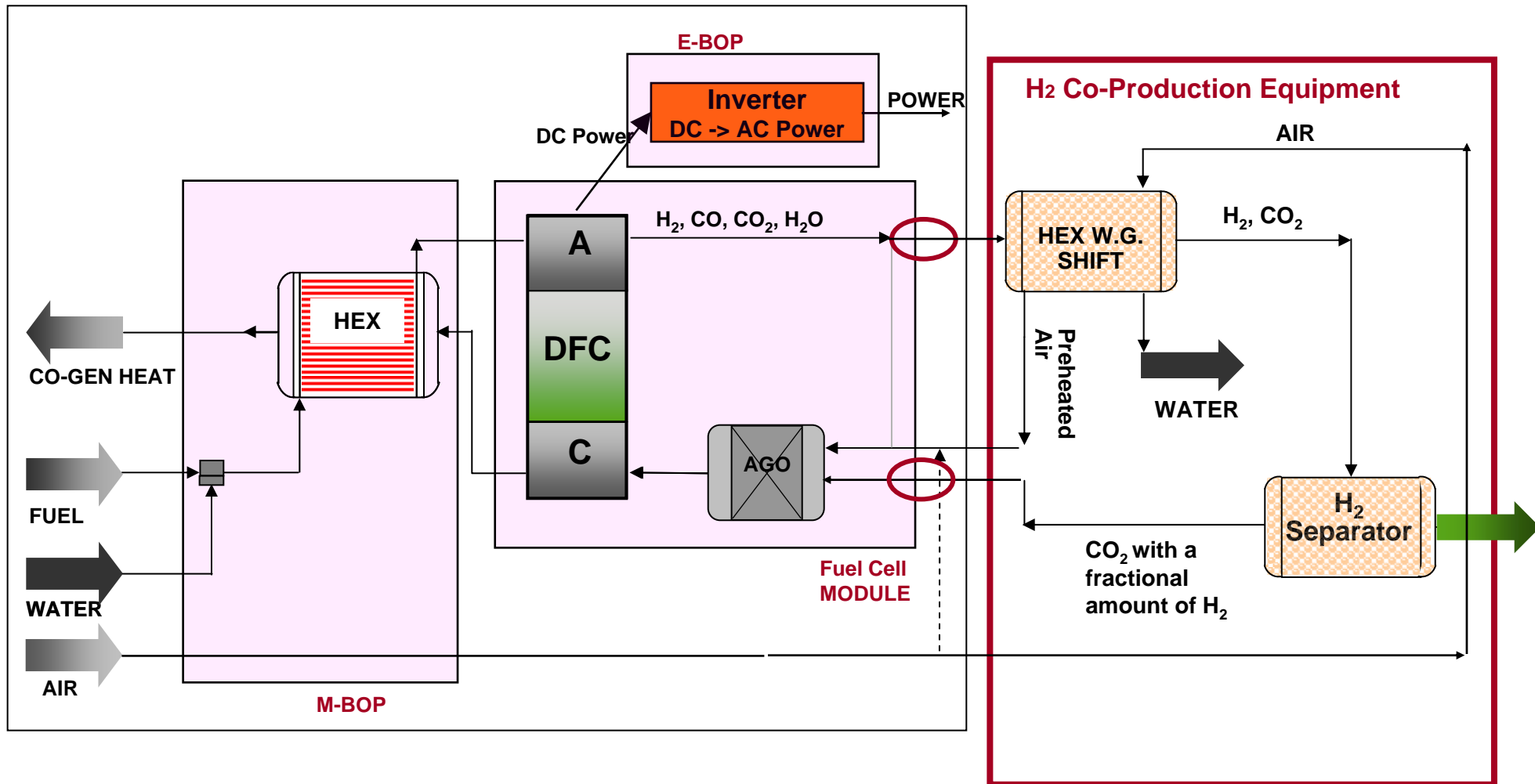



Hydrogen Co-production Challenge

- **Start- Anode Outlet**

H₂: 10%

H₂O: 40%

CO: 5%

CO₂: 45%

- High Temperature
- Low Pressure



- **Product- Hydrogen**

— > 99.99 % H₂

— < 1 ppmv CO

— > 100 psig

- **Subject to Economic Balance:**

- Capital
- Hydrogen Recovery
- Parasitic Power
- Heat Recovery
- Water Recycle
- Waste Gas Integration



FuelCell Energy
Ultra-Clean, Efficient, Reliable Power

DFC-H2[®] Co-production Plant Major Subsystems

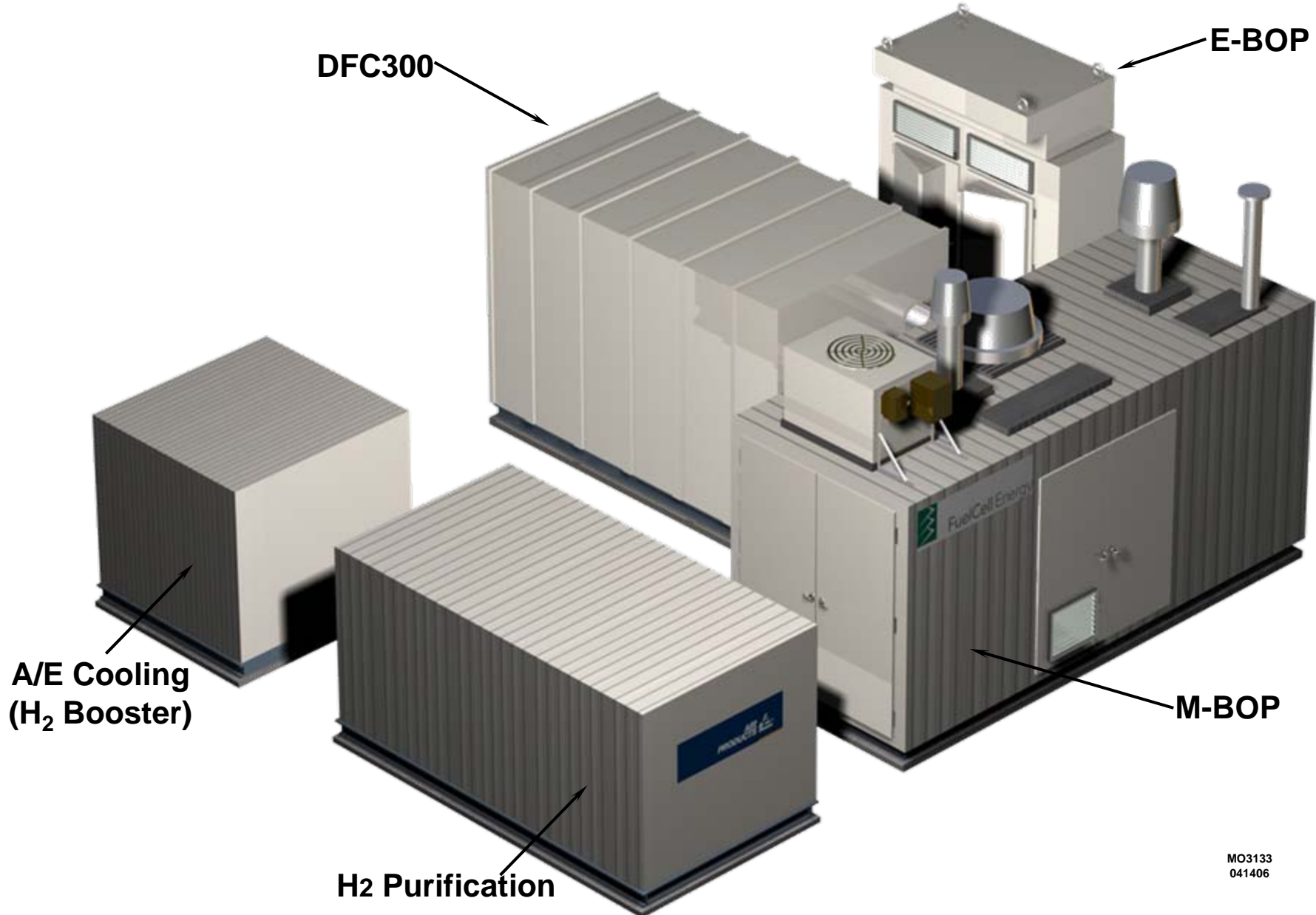



FuelCell Energy
Ultra-Clean, Efficient, Reliable Power

Submegawatt DFC-H2[®] System Components – Testing at FCE (APCI-DOE Project)



Hydrogen Ready Fuel Cell Module



Hydrogen Ready Fuel Cell Module

All Weather Design



FuelCell Energy
Ultra-Clean, Efficient, Reliable Power

DFC-H2[®] Operation Overview

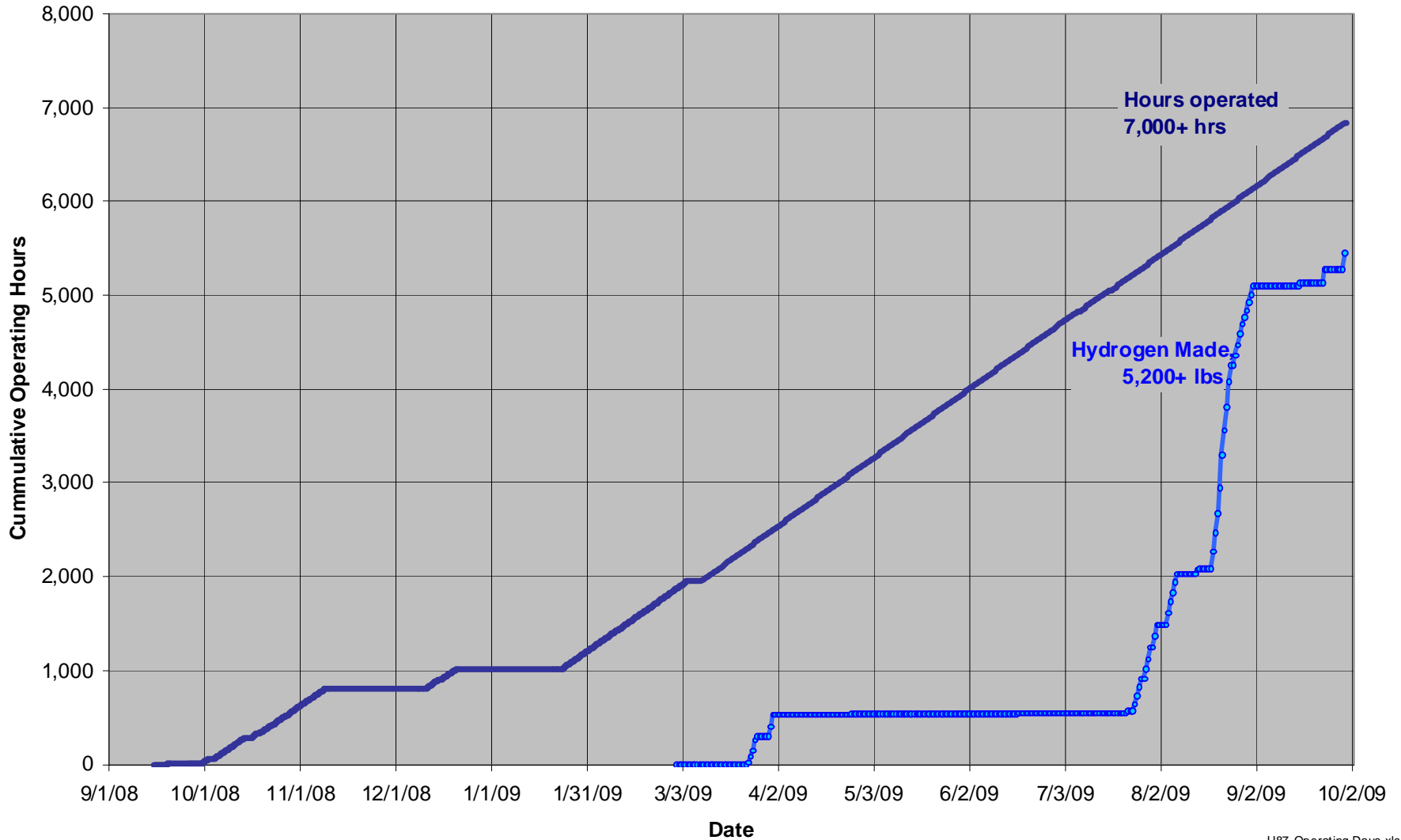

U87 Operating Days.xls

Integrated Operation Successful



- **Produced 5 to 10 lb/hr hydrogen**
Estimated hydrogen recovery at 80 to 85%
Product purity <0.2 ppm CO; <2 ppm CO₂
- **Operation with simulated digester gas feed**
PSA operating map developed (cycle time vs. feed rate)
- **Implemented automated integration and deintegration**



- Emits virtually zero pollutants (NO_x, SO_x)
- Significantly reduced CO₂
- Quiet operation suitable for almost any location

Criteria Pollutants

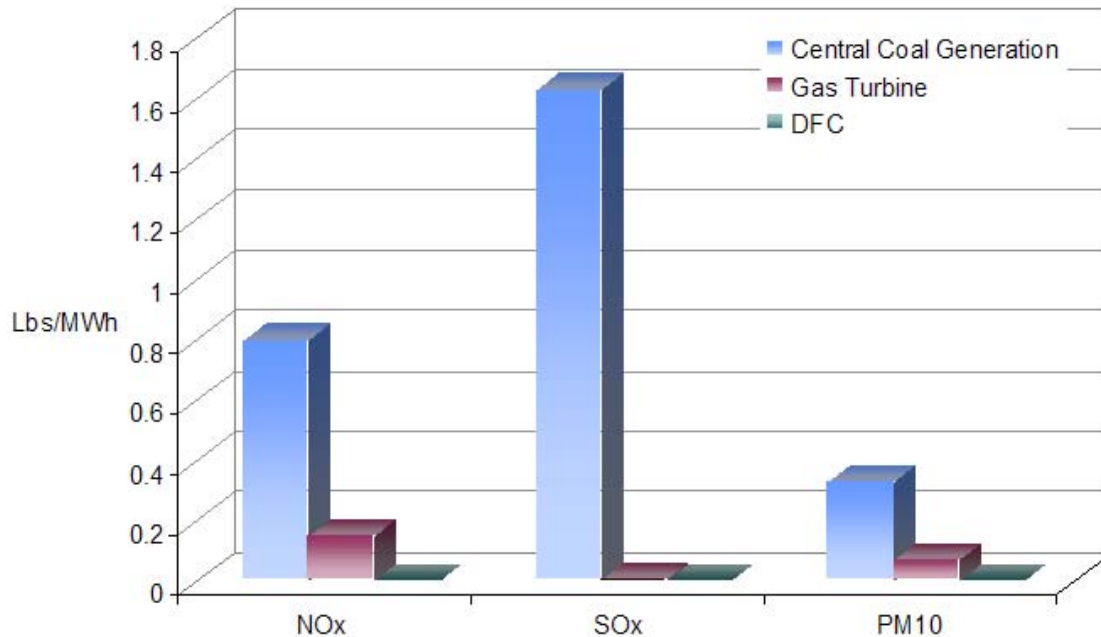

CO₂ Greenhouse Gas Emissions

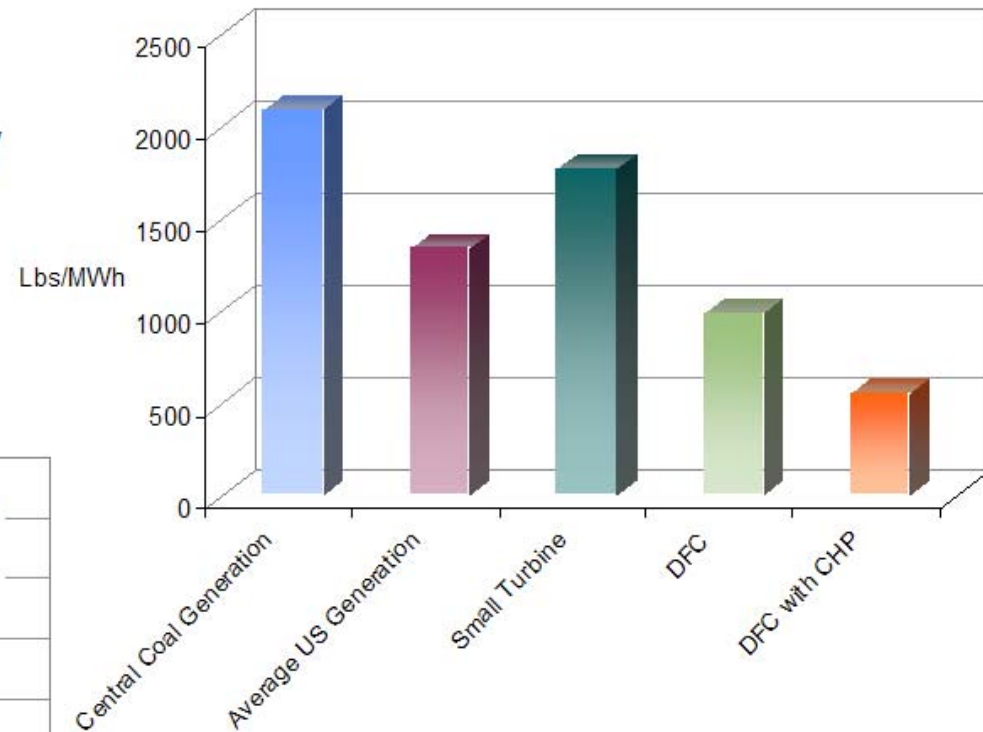

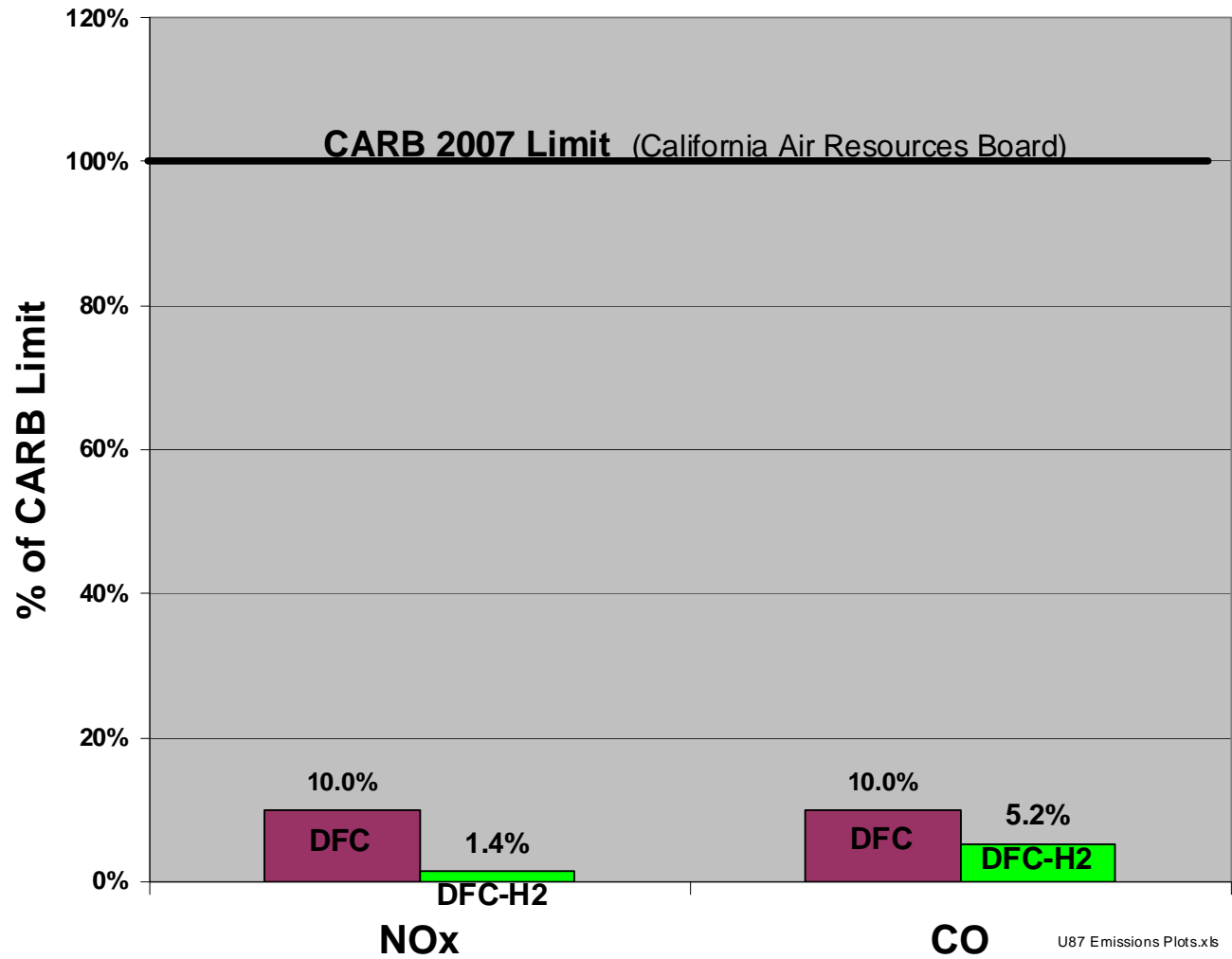

Significantly Lower Emission Than CARB2007 Limits



FuelCell Energy
Ultra-Clean, Efficient, Reliable Power

Co-Production Capacity of DFC-H₂[®] Power Plants

DFC-300[®]



DFC-1500[®]



DFC-3000[®]



Co-product

Power, kW	250	1,000	2,000
Hydrogen, kg/day	125	500	1,000
Heat, mmBtu/hr	0.5	2.0	4.0



FuelCell Energy
Ultra-Clean, Efficient, Reliable Power

Co-Production Capacity of DFC-H2[®] Power Plants

DFC300[®]



DFC1500[®]



DFC3000[®]



Co-product

Power, kW	250	1,000	2,000
Hydrogen, kg/day	125	500	1,000
Heat, mmBtu/hr	0.5	2.0	4.0

Refueling Capacity

Cars, 4.2 kg/day	30	120	240
Buses, 25 kg/day	5	20	40
Fork Lifts, 2.1 kg/day	60	240	480
Plug-in Battery Hybrid, 12 kWh/day	500	2,000	4,000



FuelCell Energy
Ultra-Clean, Efficient, Reliable Power

First DFC-H2[®] Prototype to be Demonstrated in California

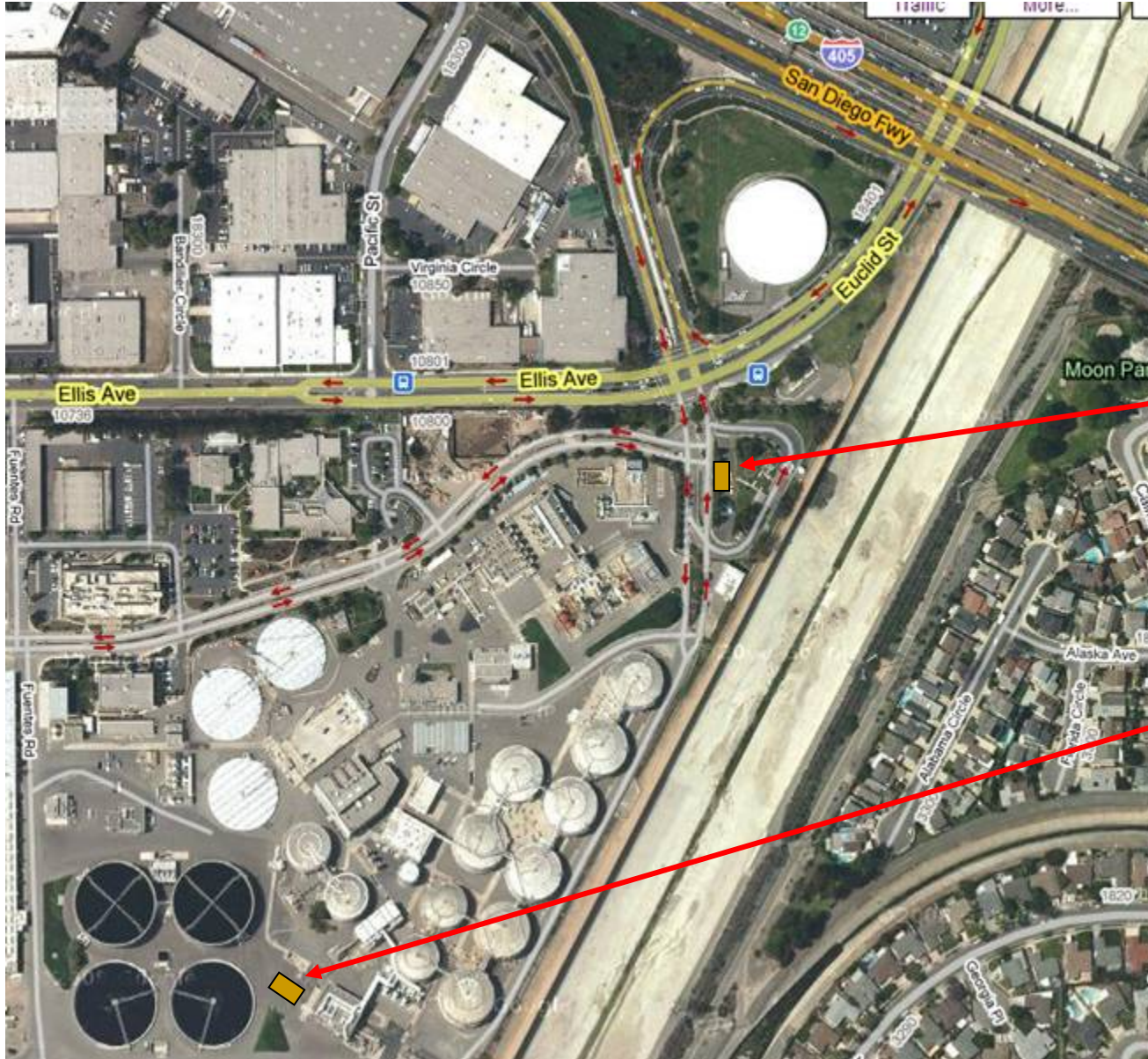

Orange County
Sanitation District
(OCSD)

Renewable H₂
Filing Station

ADG fueled
DFC-H2[®]
Production Unit





FuelCell Energy
Ultra-Clean, Efficient, Reliable Power

Advanced Hydrogen Co-production Concept

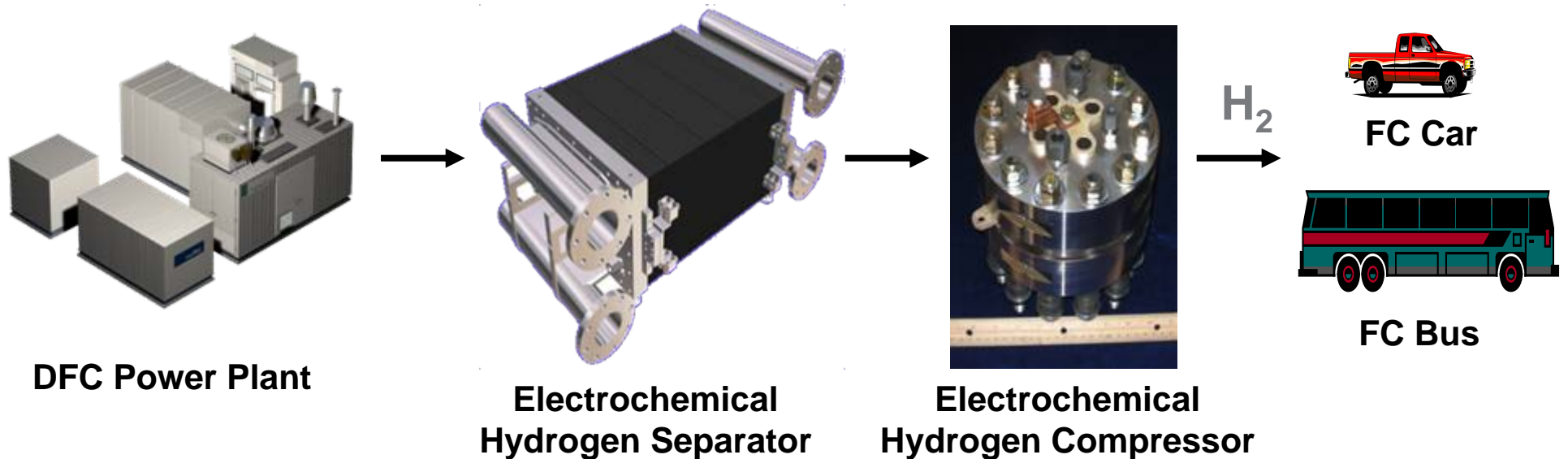

MO3145

Potentially EHS and EHC Offer Greater Reliability and Lower Operating Costs



FuelCell Energy
Ultra-Clean, Efficient, Reliable Power

Electrochemical Hydrogen Separator Development

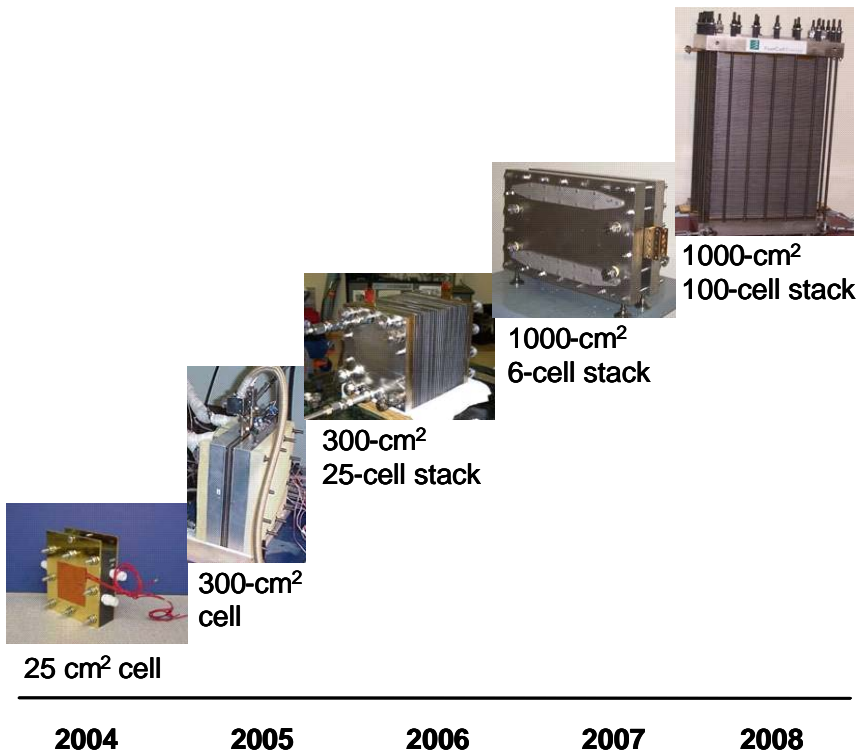

MO3188A

Technology Scale-up

Reducing Power Requirements for H₂ Separation
Subscale data from Separating H₂ from a Dilute H₂ Reformate Stream

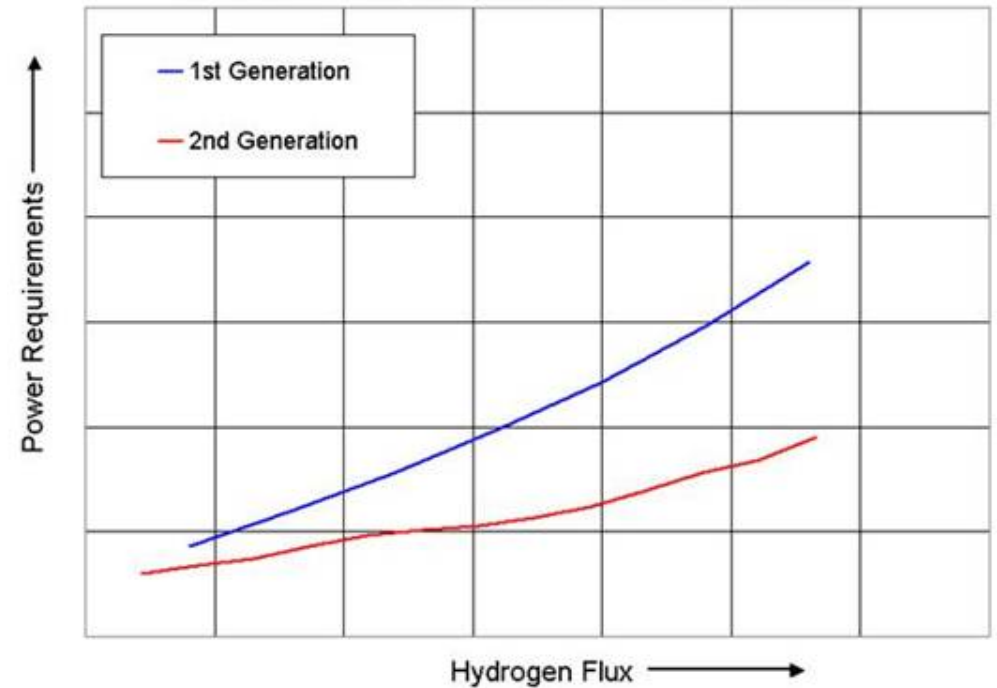

~50% Reduction in Energy Consumption



Specific Energy Consumption of Various Compressors

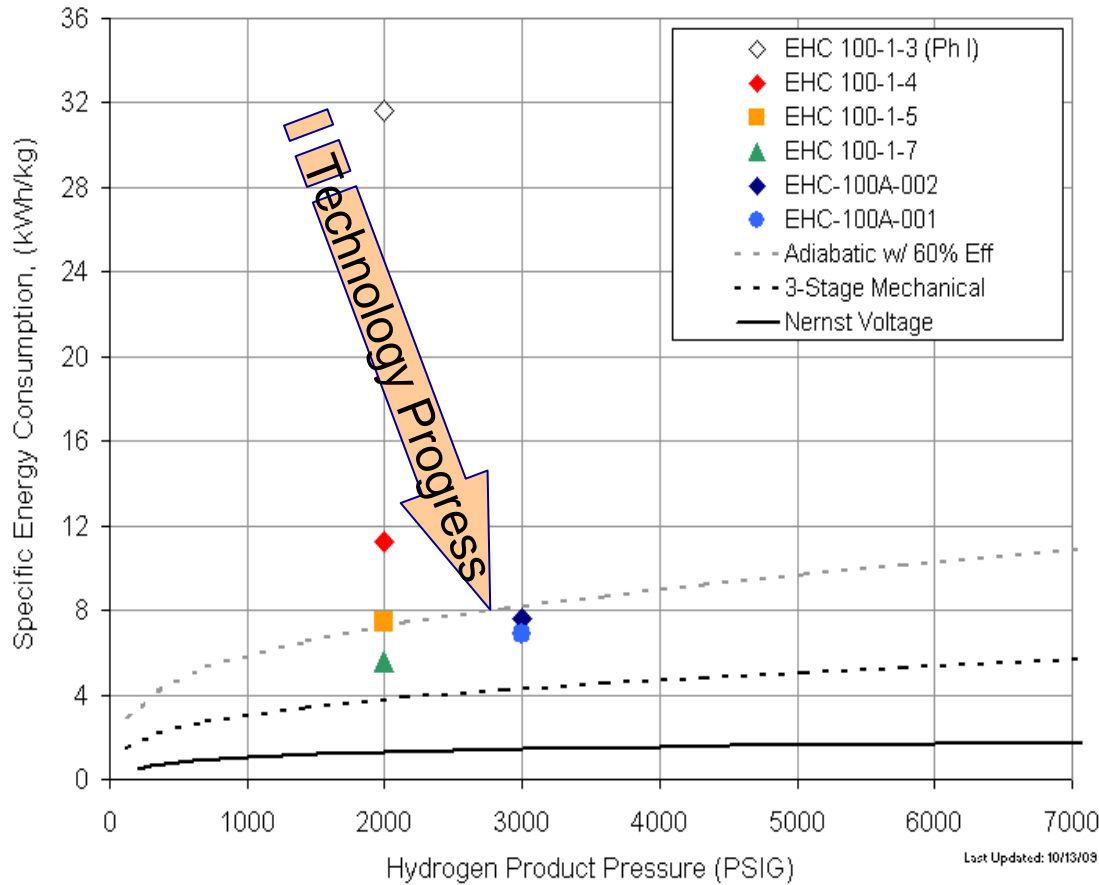

Over 80% Reduction in Compression Energy



Achieved 5,600 psi Compression in Single Stage



2009 DOE Hydrogen Program R&D Award



FuelCell Energy
Ultra-Clean, Efficient, Reliable Power

Double the Value of Renewable Fuels

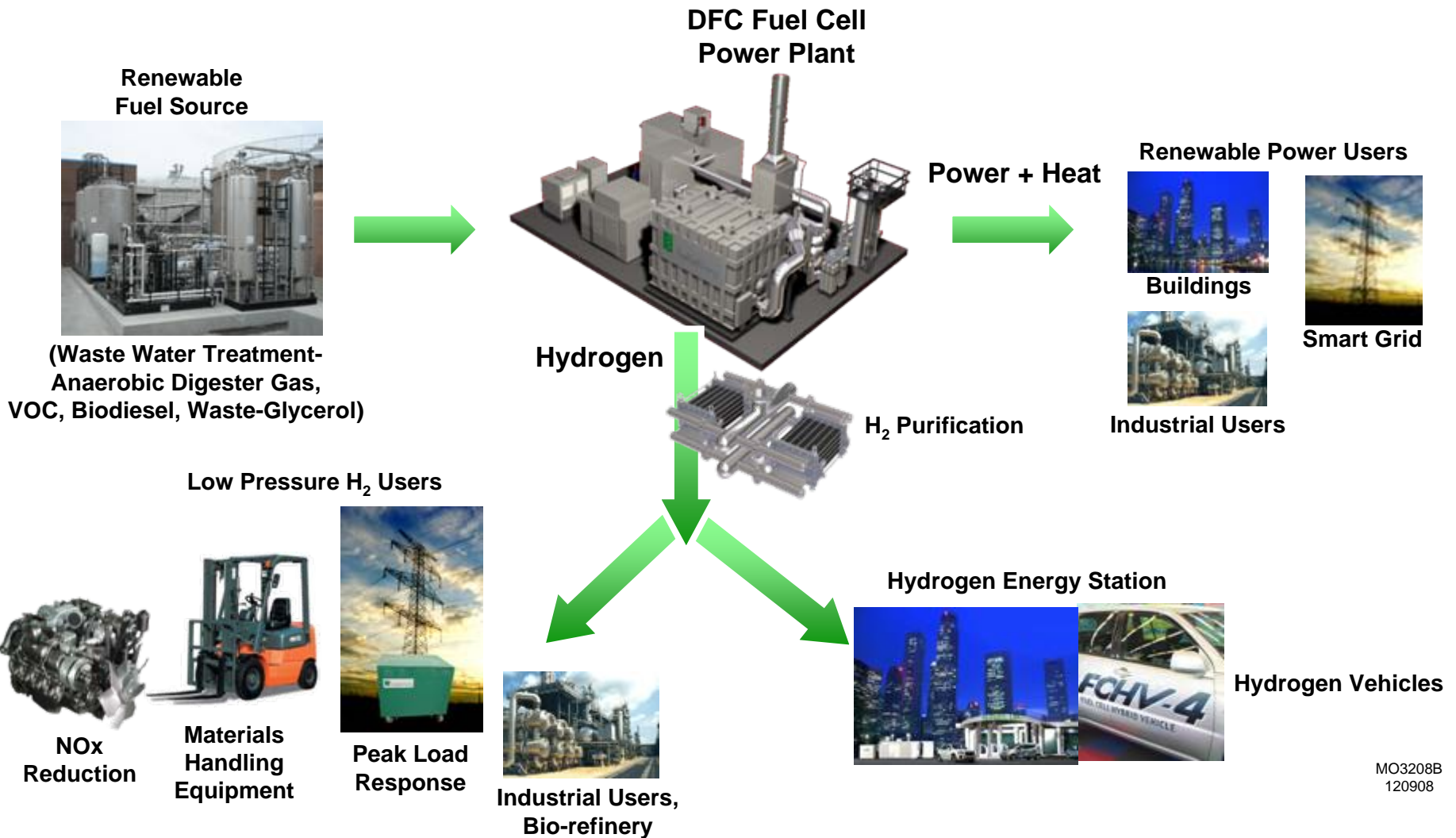

MO3208B
120908

Emerging Applications Include Smart Grid and Emission Reduction



FuelCell Energy
Ultra-Clean, Efficient, Reliable Power

DFC-H2[®] Peaker with Wind Power can Maximize Useable Renewable Power

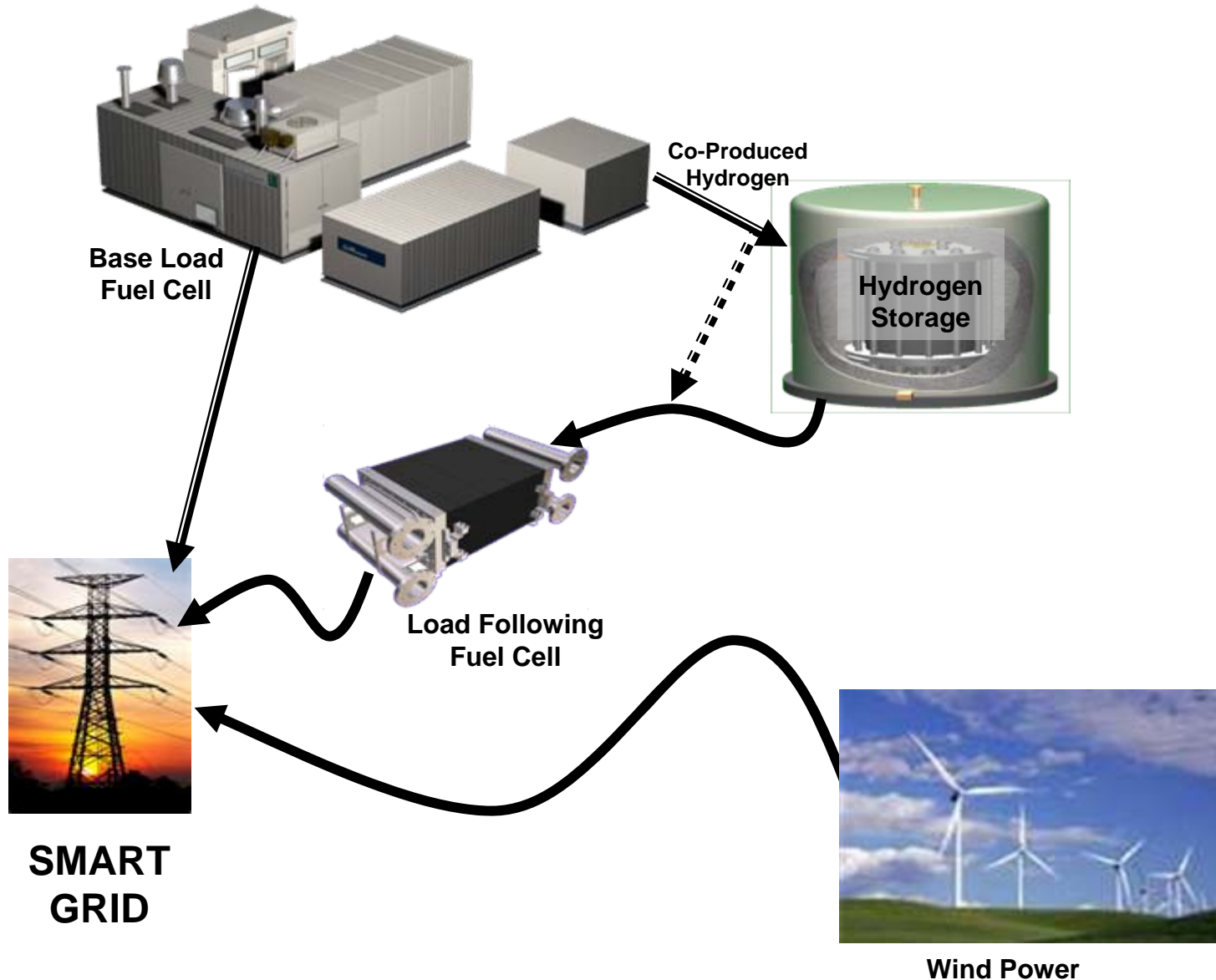



- **Hydrogen Separation System**

- Baseline PSA system demonstrated
- Advanced EHS technology promises up to 50% reduction in operating cost

- **Demonstration Status**

- A plant for co-production of hydrogen and electricity has been designed, built and tested at FCE
- Operation validated on natural gas and simulated ADG
- Operation on digester gas at a site in California is planned, including vehicle refueling

- **Applications**

- New value-added uses of hydrogen identified

For further information
contact

Pinakin Patel

ppatel@fce.com

203-825-6072

