

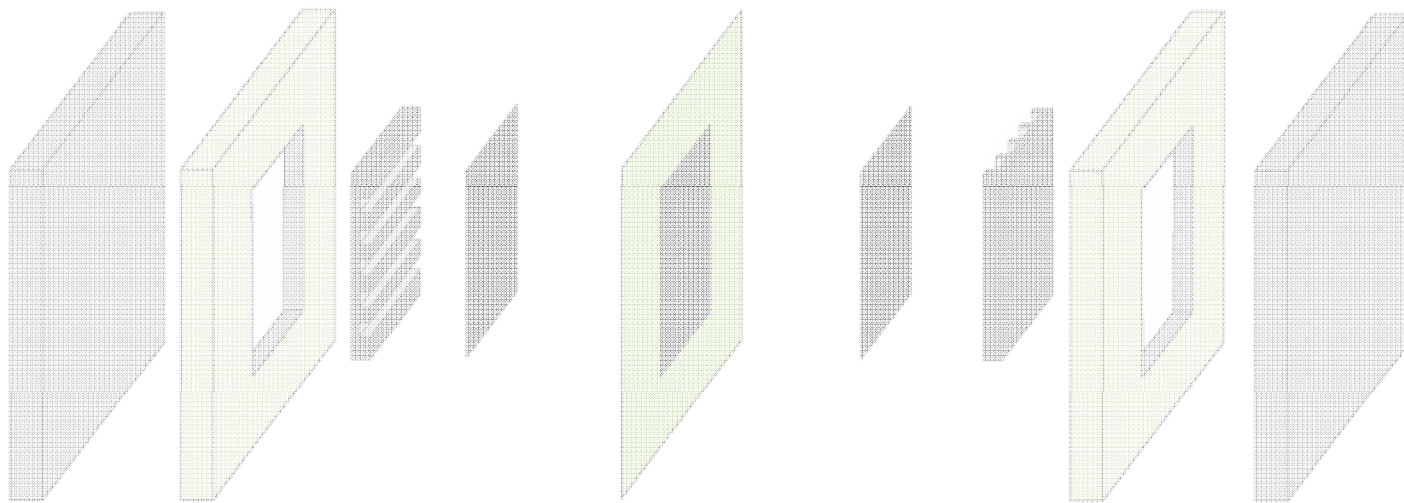

PEM Fuel Cell Design, Fabrication and Testing in an Undergraduate Engineering Course



Denise McKay
Assistant Professor, Smith College

Etta Grover-Silva '10
Smith College



Engineering Science Curriculum

EGR 410D
Design Clinic

300 Level Electives
3 Technical Electives required

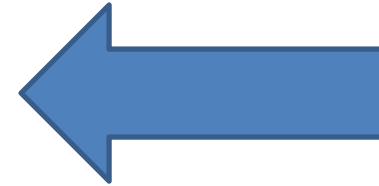

EGR 374
Fluids

EGR 375
Strength
of
Materials

EGR 320
Signals
and
Systems

EGR 363
Mass
and Heat
Transfer

EGR 326
Dynamic
Systems

EGR 220
Engineering
Circuit
Theory

EGR 260
Energy and
Mass
Balances

EGR 270
Engineering
Mechanics

EGR 290
Engineering
Thermo -

EGR 100
Engineering
For
Everyone

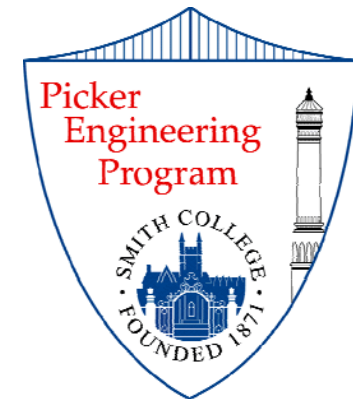



Fuel Cell Course Overview

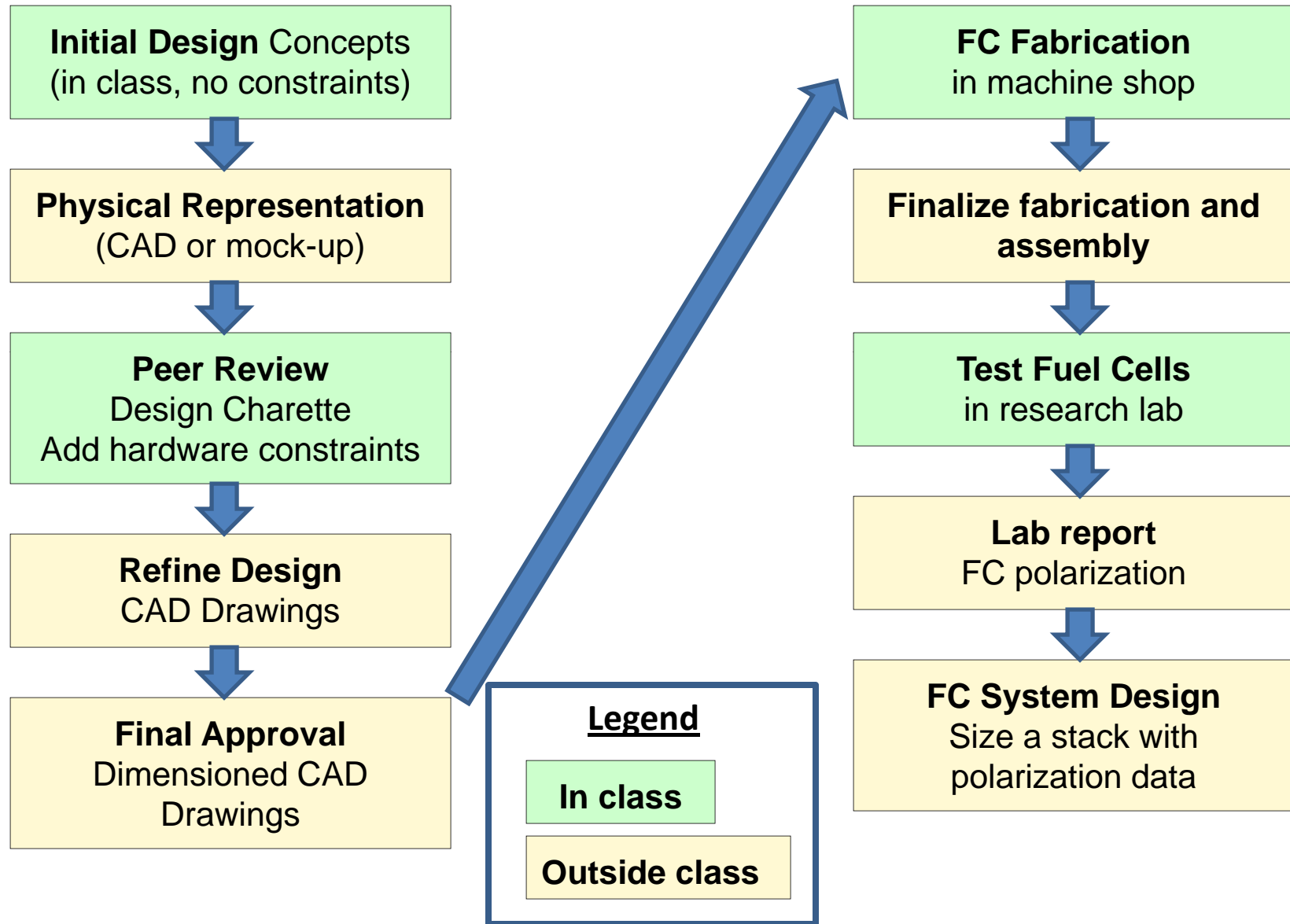



FC Design – Background Materials

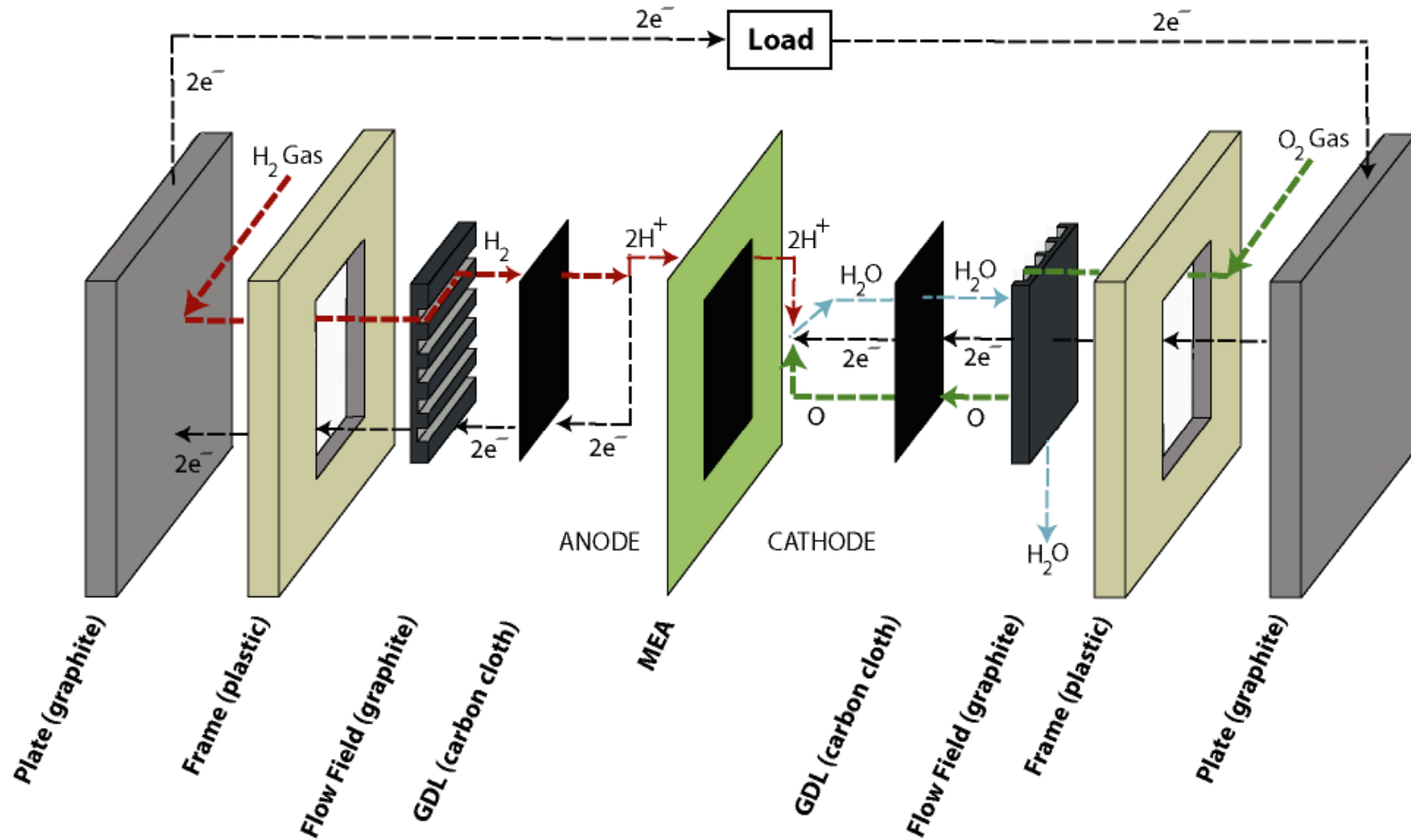

Initial Design Objectives:

- Electrical conduction
- Reactant distribution from plumbing fitting to catalyst layer
- Gas sealing



FC Design – Design Ideation

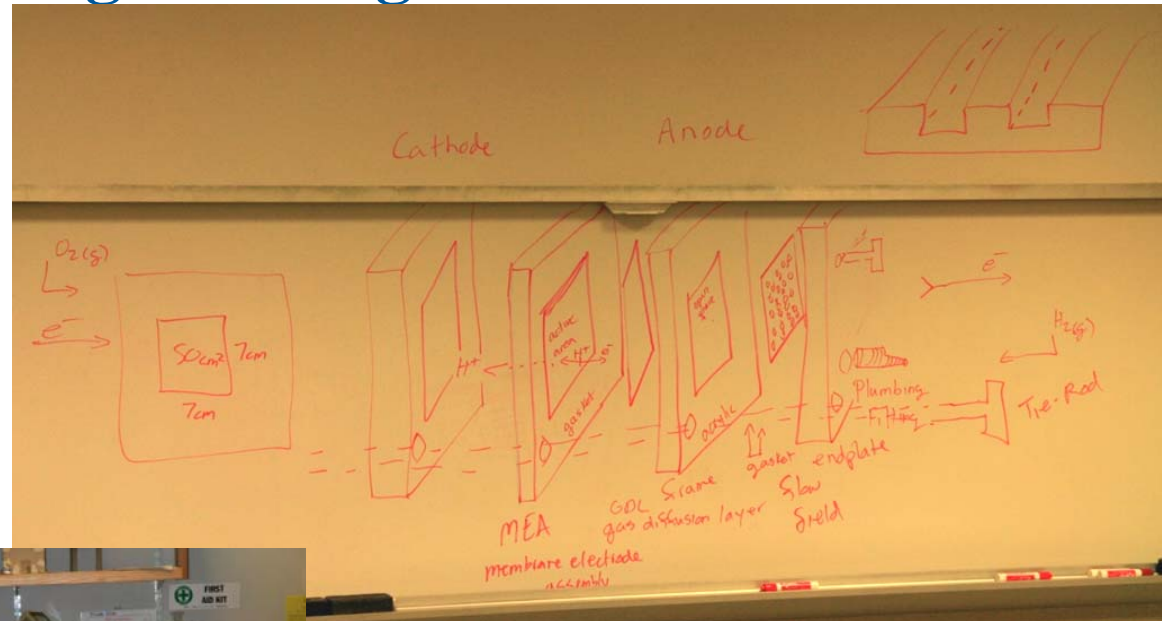

Given materials and dimensions

- Gasketed MEA – 50cm² active area
- GDL – cloth with integrated MPL
- Gaskets – Buna-N sheets
- Flow Field/Current collector – metal screens or perforated metal
- Endplate – acrylic/Lexan
- Hardware – threaded rod, wing nuts, bolts, hose/barb fittings



FC Design – Physical Representation

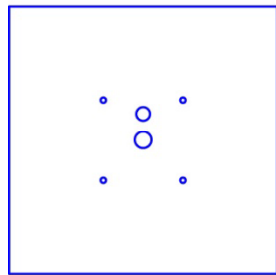

End plate
Center input O₂ (ait), 0.312" rad
4 small holes, 0.1" rad output O₂/air
vertical offset center hole- conduction bolt hole- 0.255"
Thickness Endplate .2" (semi-arbitrary)

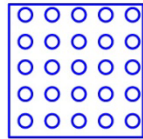

flow field
5x5cm
25 holes, 0.25cm rad each
thickness ??

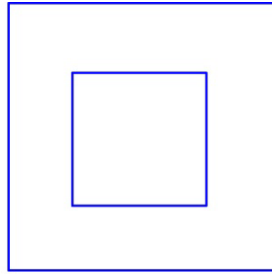

gasket
10cmx10cm outer, 5x5cm inner hole,
thickness 0.005"

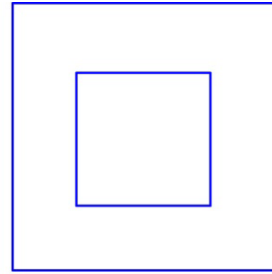

Cathode Frame
10cmx10cm outer, 5x5cm inner hole,
thickness .1" (kind of arbitrary, but to allow for
tie-rod to pass all the way through)

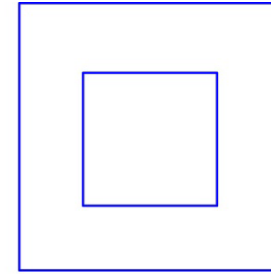

2 gasket layers
10cmx10cm outer, 5x5cm inner hole,
thickness 0.009" $\frac{1}{2}$ MEA + GDL, since each
gasket is ~0.005" thick, we need 2



GDL 5.1x5.1cm
0.0013"

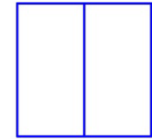

MEA 5.0cmx5.0cm
0.0015" thick

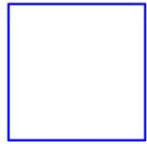

GDL 5.1x5.1cm
0.0013"

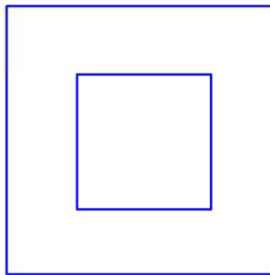

2 gasket layers
10cmx10cm outer, 5x5cm inner hole,
thickness 0.009" $\frac{1}{2}$ MEA + GDL, since each
gasket is ~0.005" thick, we need 2

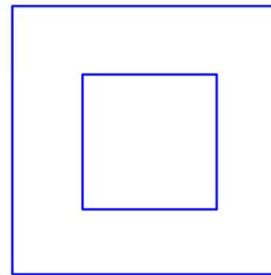

Anode Frame
10cmx10cm outer, 5x5cm inner hole,
thickness .1" (kind of arbitrary, but to allow for
tie-rod to pass all the way through)

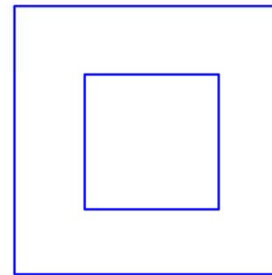

gasket
10cmx10cm outer, 5x5cm inner hole,
thickness 0.005"

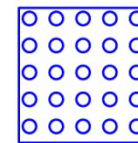

flow field
5x5cm
25 holes, 0.25cm rad each
thickness ??

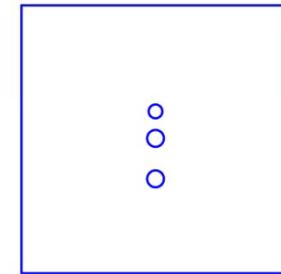

End plate
Center input H₂ (air), 0.312" rad
lower hole, 0.312" rad output H₂
vertical offset center hole- conduction bolt hole- 0.255"
Thickness Endplate .2" (semi-arbitrary)



FC Design – Design Charette



Refine cell design directly with instructor prior to fabrication



Fabrication and Assembly



Laser cut endplates



Water Jet Cutter



Tapping endplates



Assembly



Final Assembly



Machine Shop



Performance Characterization – Test Cells

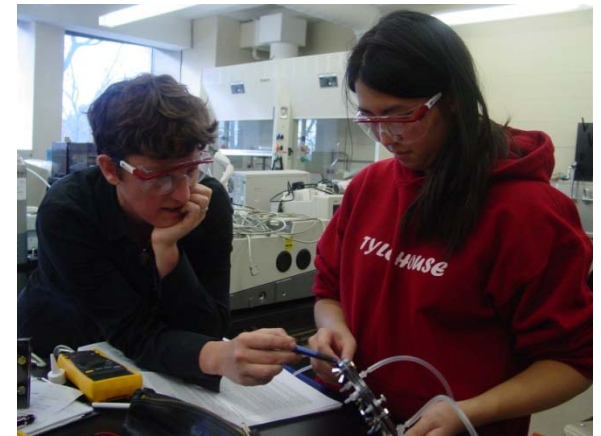
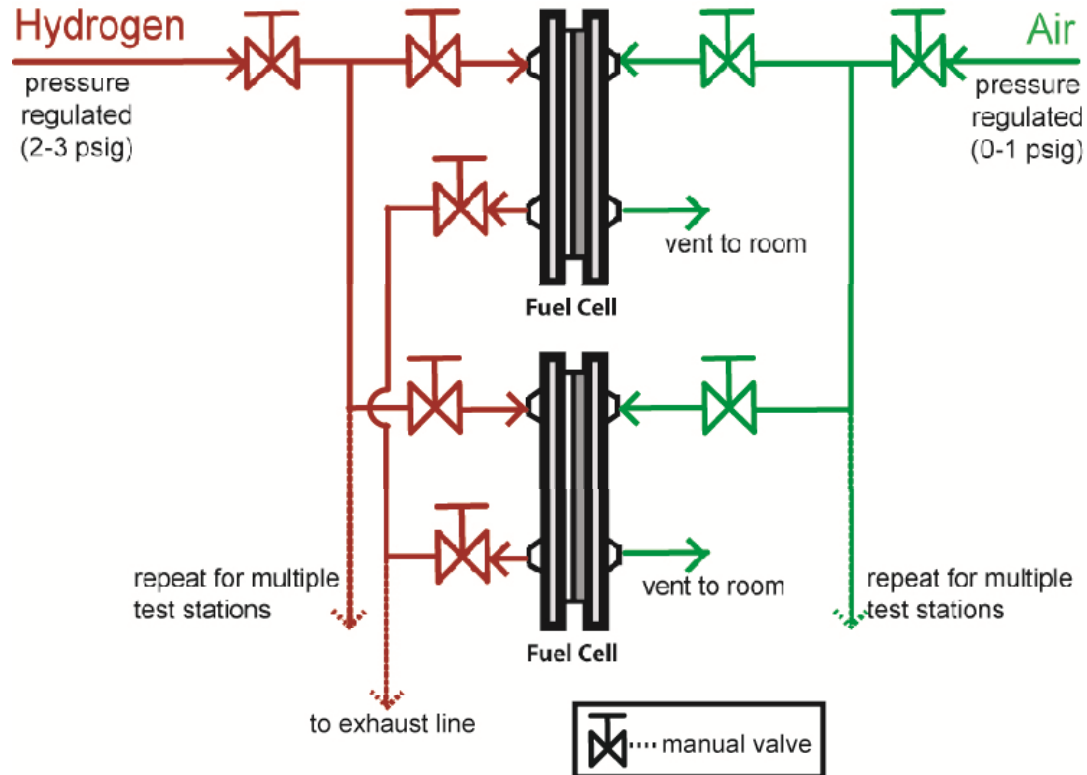



Application of Test Data to FC System Design

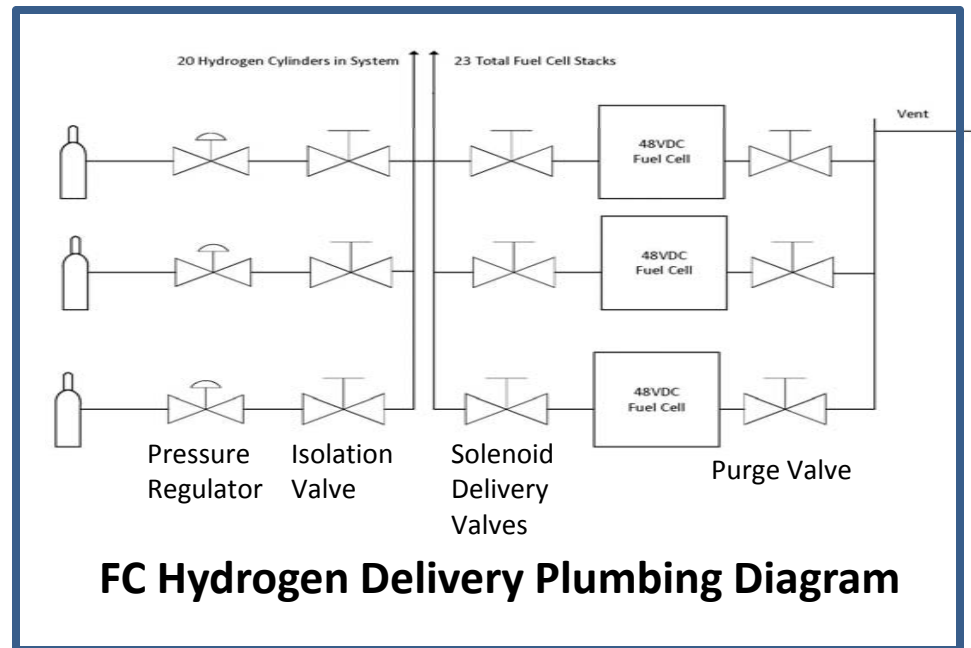
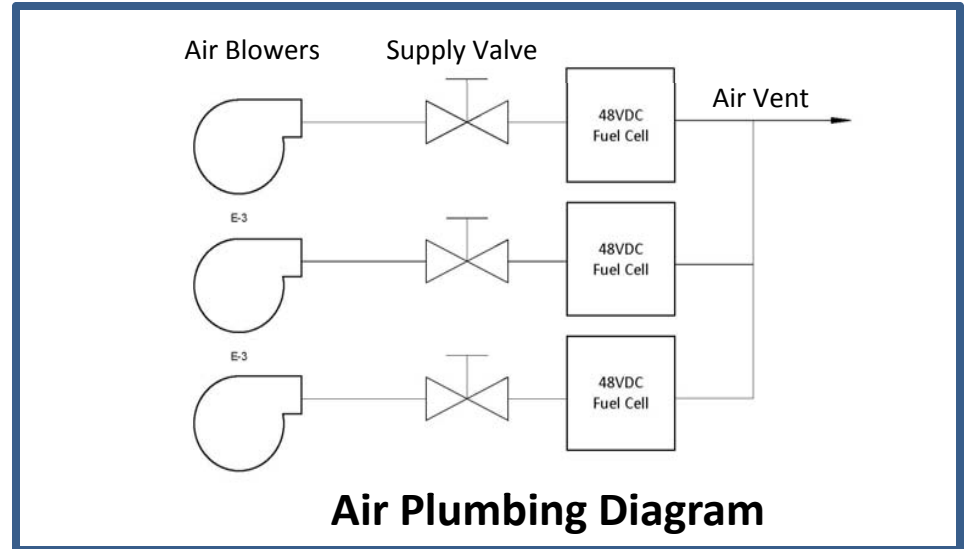
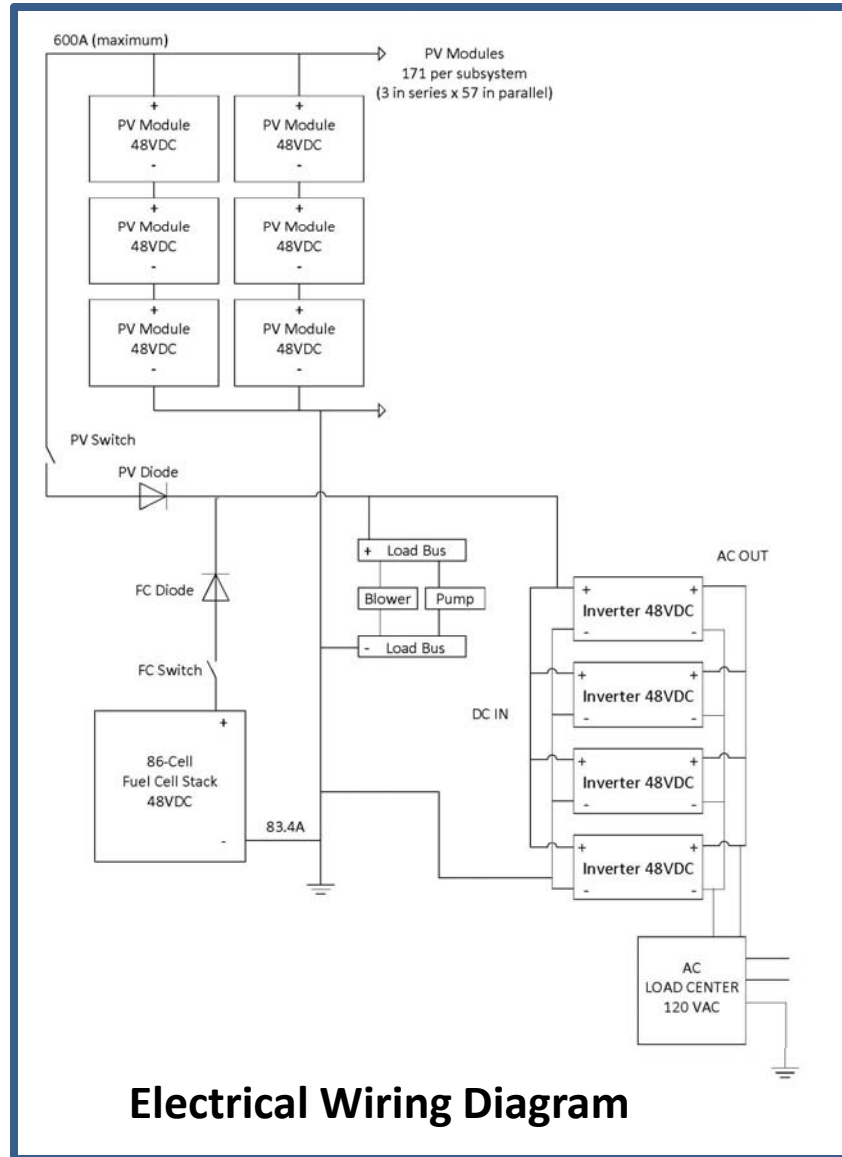



Life Cycle Cost Assessment

Item	Single Present Worth Year	Uniform Present Worth Year	Cost	Present Worth Factor	Present Worth Amount		
Initial Costs							
PV Equipment	0		\$4,006,030	1.0	\$4,006,030		
FC Equipment *	0		\$1,621,110	1.0	\$1,621,110		
Installation Cost	0		\$82,800	1.0	\$82,800		
Annual Costs							
Annual Maintenance	0	20	\$5,520	11.5	\$63,314		
Repair & Replacement							
H ₂ Fuel †	1		\$81,050	0.94	\$76,462		
H ₂ Fuel †	2	Water Pump Replacement	10		\$3,910	0.56	\$2,183
H ₂ Fuel †	3	Water Pump Replacement	12		\$3,910	0.50	\$1,943
H ₂ Fuel †	4	Water Pump Replacement	14		\$3,910	0.44	\$1,729
H ₂ Fuel †	5	Water Pump Replacement	16		\$3,910	0.39	\$1,539
H ₂ Fuel †	6	Water Pump Replacement	18		\$3,910	0.35	\$1,370
H ₂ Fuel †	7	Air Blower Replacement	2		\$16,100	0.89	\$14,329
H ₂ Fuel †	8	Air Blower Replacement	4		\$16,100	0.79	\$12,753
H ₂ Fuel †	9	Air Blower Replacement	6		\$16,100	0.70	\$11,350
H ₂ Fuel †	10	Air Blower Replacement	8		\$16,100	0.63	\$10,101
H ₂ Fuel †	11	Air Blower Replacement	10		\$16,100	0.56	\$8,990
H ₂ Fuel †	12	Air Blower Replacement	12		\$16,100	0.50	\$8,001
H ₂ Fuel †	13	Air Blower Replacement	14		\$16,100	0.44	\$7,121
H ₂ Fuel †	14	Air Blower Replacement	16		\$16,100	0.39	\$6,338
H ₂ Fuel †	15	Air Blower Replacement	18		\$16,100	0.35	\$5,641
H ₂ Fuel †	16	Air Blower Replacement	18		\$16,100	0.35	\$5,641
H ₂ Fuel †	17	Air Blower Replacement	18		\$16,100	0.35	\$5,641
H ₂ Fuel †	18	23 FC Stacks Replacement	3		\$900,000	0.84	\$755,657
H ₂ Fuel †	19	23 FC Stacks Replacement	6		\$900,000	0.70	\$634,464
Inverter Replacement	5	23 FC Stacks Replacement	9		\$900,000	0.59	\$532,709
Inverter Replacement	10	23 FC Stacks Replacement	12		\$900,000	0.50	\$447,272
Inverter Replacement	15	23 FC Stacks Replacement	18		\$900,000	0.35	\$315,309
Water Pump Replacement	2	23 FC Stacks Replacement	18		\$900,000	0.35	\$315,309
Water Pump Replacement	4	23 FC Stacks Replacement	18		\$900,000	0.35	\$315,309
Water Pump Replacement	6	23 FC Stacks Replacement	18		\$900,000	0.35	\$315,309
Water Pump Replacement	8	23 FC Stacks Replacement	18		\$900,000	0.35	\$315,309
Salvage Value							
Water Pump Replacement	8	Salvage is 10% of Initial Equipment Cost	20		-\$400,603	0.31	-\$124,910
Total Life Cycle Cost							\$10,181,495



Summary

We have developed and implemented an upper division fuel cell engineering course where students:

- apply fundamental science to fuel cell applications,
- design, develop and fabricate their own PEM fuel cell,
- test their design through polarization data,
- apply single cell data in the sizing of large fuel cell stacks, and
- demonstrate an integrated understanding of complex processes.

As engineers are increasingly challenged to apply theoretical principles to complex and multidisciplinary problems, a curriculum that teaches knowledge integration and system level design across scales is critical to their future success.



Acknowledgements

We quite graciously acknowledge:

- Smith College for considering this course as a permanent offering,
- Picker Engineering Program for providing tremendous financial and technical support in developing this course in the Fall 2008,
- Center for Design and Rapid Prototyping for providing constant access to shop equipment and support throughout the fabrication phase





Performance Characterization – Test Systems

